

MAKPRIS

tutto
nasce da
un'idea.

everything comes from an idea.

MAKRIS
CUSTOM DESIGN CONCEPT

L



K



La migliore **innovazione tecnologica** del brand Imoon si fonde con la libertà di creare forme nuove di Makris, per dar luce a **inedite soluzioni, che trasformano idee in progetti concreti**. Originalità, voglia di lasciarsi ispirare, senza limiti né convenzioni: **ogni progetto, su misura**, è studiato per comunicare al meglio **stile e personalità del Retailer** e coinvolgere il consumatore in una **Store experience unica ed esclusiva**.

Il Team Makris è costituito da **designer, architetti e scenografi uniti da una passione comune** per la perfezione nell'abbinare inconsuete forme a materiali differenti per tipologia e finitura. Una **visione futurista che sublima l'illuminazione a fattore decisivo** nella creazione di un'atmosfera suggestiva e ad emblema di ambienti coinvolgenti e dalla forte identità visiva.

*The best **innovation** of the Imoon brand fuses with the freedom to create new Makris shapes, to give light to brand **new solutions which transform ideas into concrete projects**. Originality, the desire to be inspired, without limits or conventions: each bespoke project is studied to communicate in the best possible way the **Retailer's style and personality** and to involve the consumer in a unique and **exclusive Store experience**.*

*The Makris Team is composed of **designers, architects and set designers joined by a common passion** for perfection in combining unusual shapes to materials of different types and finishes. A **futuristic vision which exalts lighting as a decisive factor** in the creation of an evocative atmosphere and as an emblem of **enthraling environments with a strong visual identity**.*



MAKRIS

CUSTOM DESIGN CONCEPT





think

Pensare prima di agire. Un mantra che si perde nella storia personale di ogni essere umano e arriva a descrivere il resoconto quotidiano di ogni professionista Makris. Il tentativo di **concretizzare un'idea, rendendone la risposta reale.** Rendendola luce.

Think before acting. A mantra which is lost in the personal history of every human being and which describes the daily statement of every Makris professional. The attempt to put an **idea into something concrete, making it a true response.** Turning it into light.

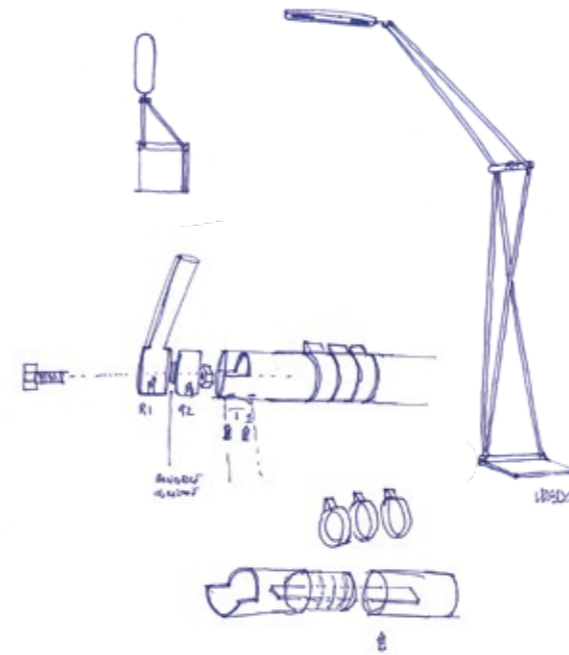

L'immaginazione diventa **esperienza percepibile e percettiva.** Dal concept, alla scelta dei materiali fino ad arrivare al montaggio, Makris crea l'universo luce adatto per ogni tipo di ambiente.

*Imagination becomes a **perceptible and perceptive experience.** From concept and the choice of materials up to installation, Makris creates the ideal lighting universe for every type of environment.*

create



work in progress

Tempo, spazio e realizzazione. Un affondo sulla realtà Makris, sul metodo di lavoro e sulla quotidiana produzione in diverse dimensioni e finiture dei prodotti custom e a catalogo. La realtà di un **laboratorio ad alta precisione**.

*Time, space and realisation. A plunge into the Makris reality, into the work method and daily production in different sizes and finishes of customised products and those available in the catalogue. The reality of a **high precision laboratory**.*

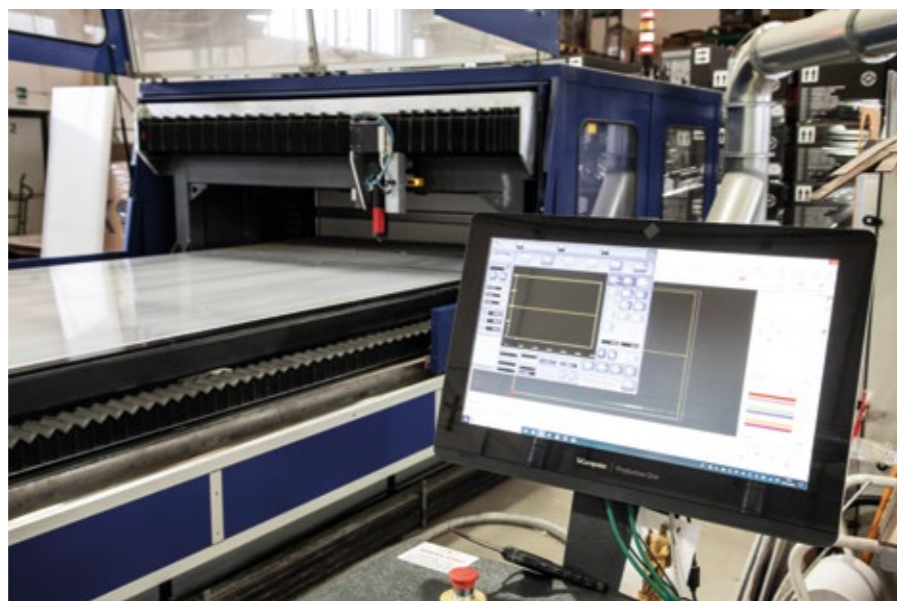
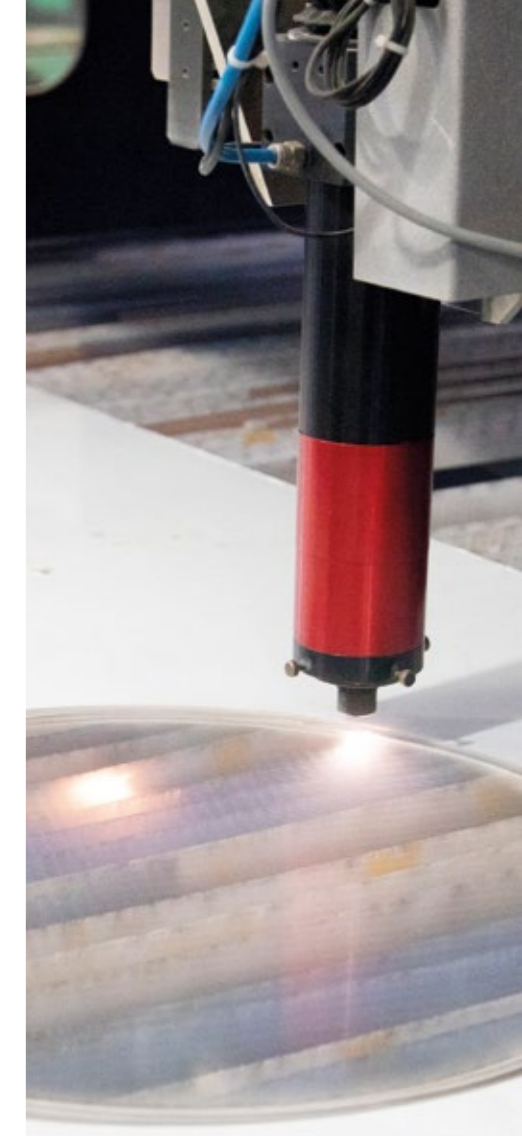

custom

La punta di diamante di Makris è una **visuale a tutto tondo sul mondo della personalizzazione**. Una fucina, dove **l'expertise si sposa con le necessità tecniche, spaziali ed estetiche** dell'ambiente e con le esigenze dei clienti.

*Makris' spearhead is an **all-round view of the personalisation world**. A source, where **expertise blends the technical, special and aesthetic needs** of the environment with the needs of the clients.*

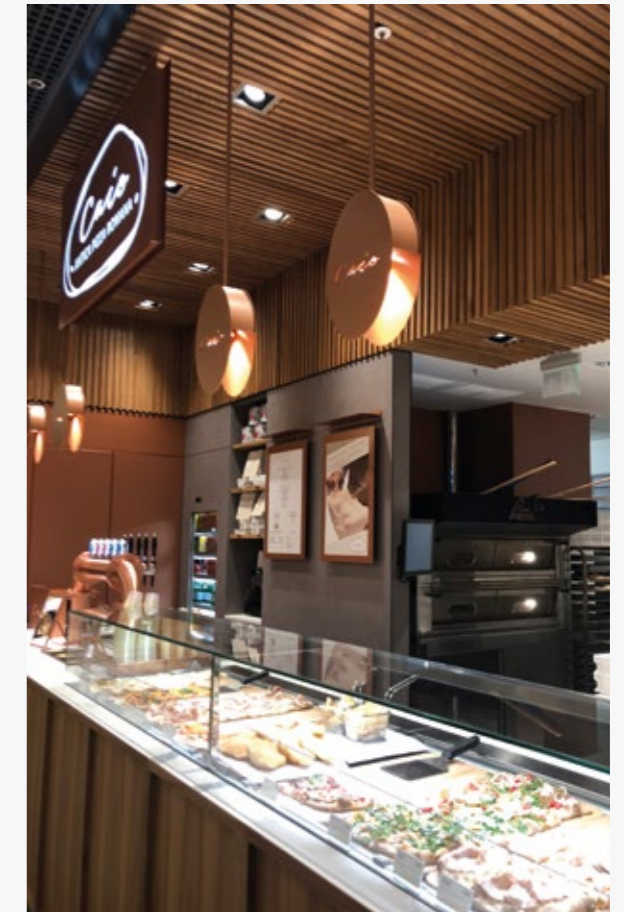
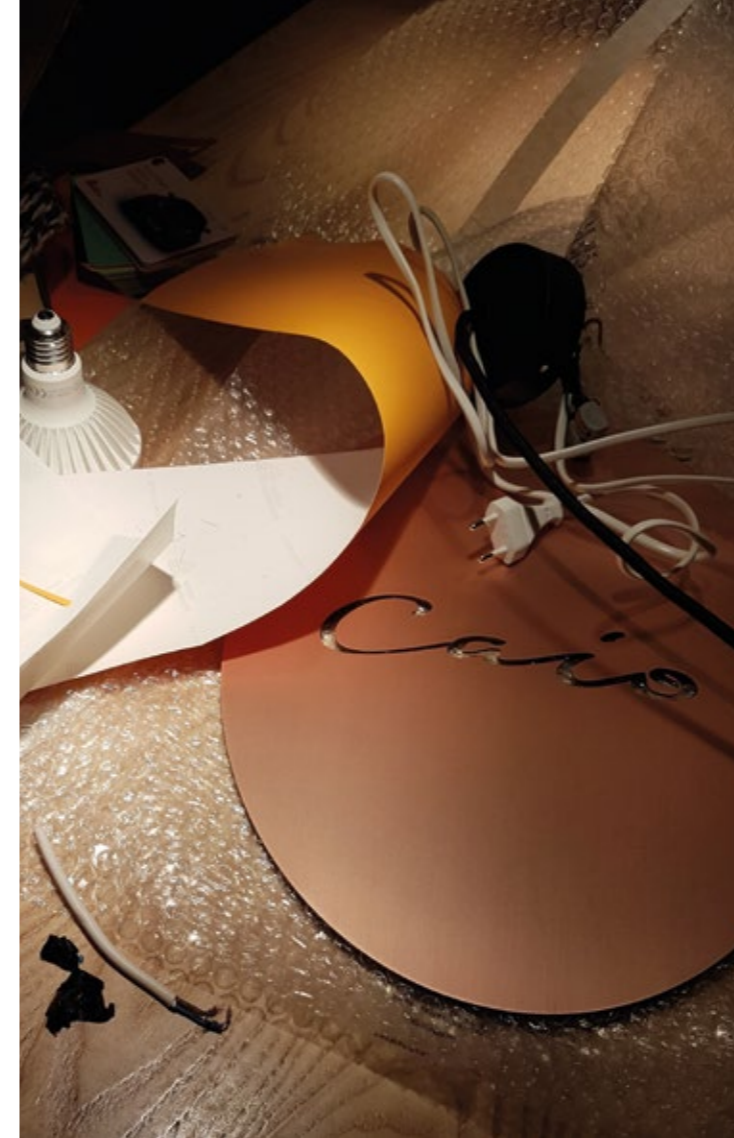
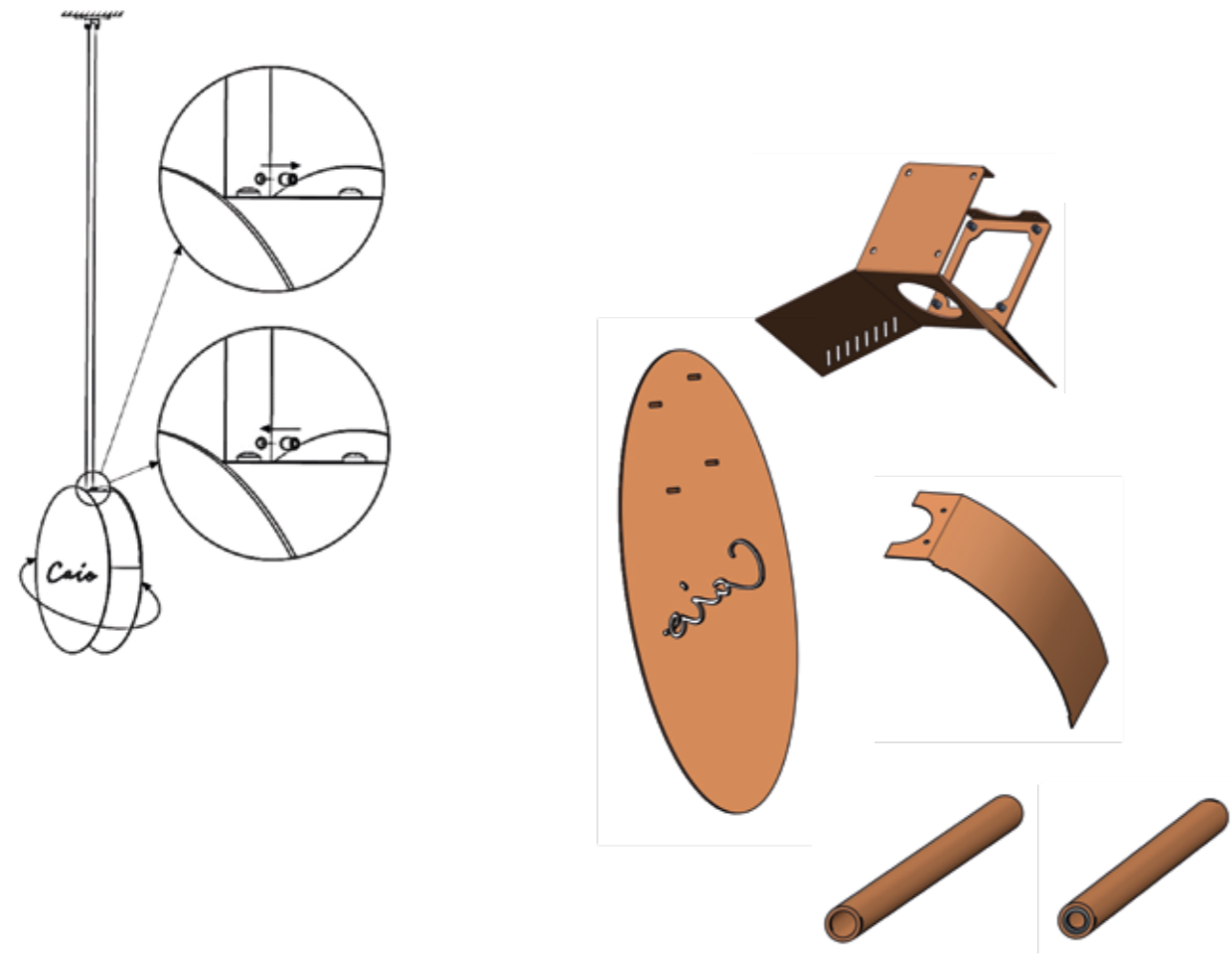

Dal **disegno al prodotto, al progetto illuminotecnico finito**. Non in step separati, ma facenti parte di un unico pensiero fluido e non partizionato. In questo modo, la visione completa di Makris risulta vincente e unica, evidenziando come marchio di fabbrica la **customizzazione di ogni processo di lavoro**.

*From **design to product, to the end technical-lighting project**. Not in separate steps, but forming part of a single fluid and undivided thought. In this way, the complete vision of Makris is successful and unique, highlighting the **customisation of every work process** as the manufacturing brand.*

Ogni ambiente è un'opportunità.
Il catalogo Makris è un **compendio tra la garanzia dei prodotti continuativi e la duttilità della customizzazione** step by step.

*Each environment is an opportunity.
The Makris catalogue is a **compendium between the guarantee of on-going products and the flexibility of step-by-step customisation.***

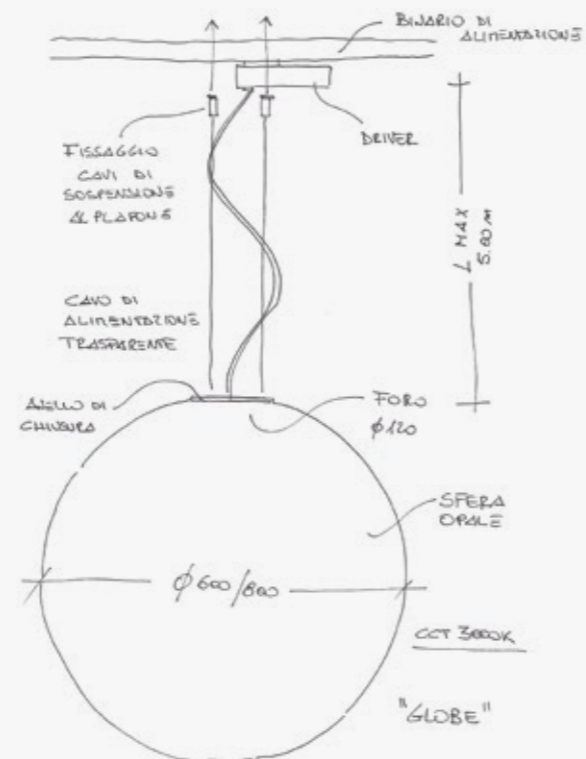
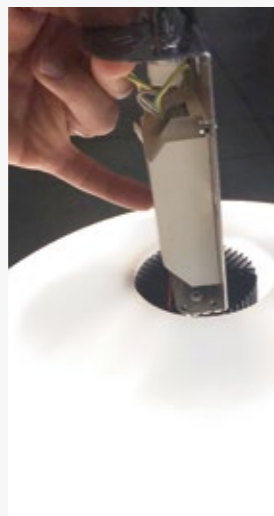

concept

il custom diventa realtà

Alcuni prodotti nascono con un'anima adatta a un solo progetto. Altri nascono si custom, ma con respiro funambolico che ben si adatta ad un passaggio di status e di applicazione. Molti prodotti custom diventano, così, prodotti a catalogo.

customisation becomes reality

Some products hide a soul suited to one single project. Others definitely hide customisation, but with an acrobatic style which adapts well to a change in status and application. In this way, many customised projects become catalogue products.





Il design deve essere al servizio delle persone. Sia dal punto di vista funzionale, sia dal punto di vista estetico. L'attenzione di Makris si dirige, quindi, sul **disegno dei prodotti** e sulla **progettazione dell'impianto illuminotecnico**, creando soluzioni espositive adatte al luogo che le accoglie e agli utenti che le vivono.

*Design must be at the service of individuals. Both from the functional and the aesthetic point of view. Makris' attention is therefore focused on the **design of products** and on the **planning of the technical-lighting installation**, creating display solutions suited to the place where they will be installed and their users.*

special project



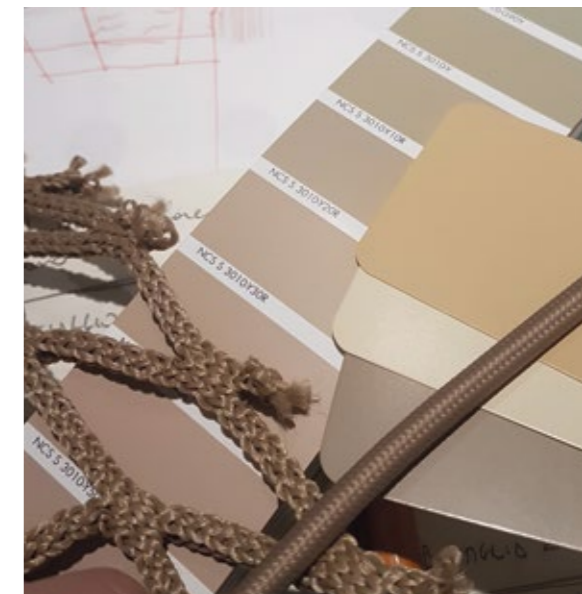
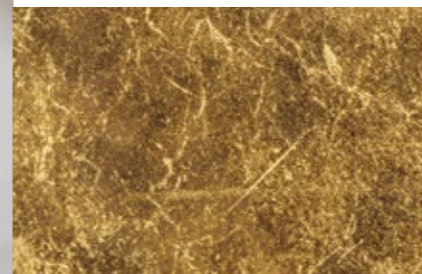
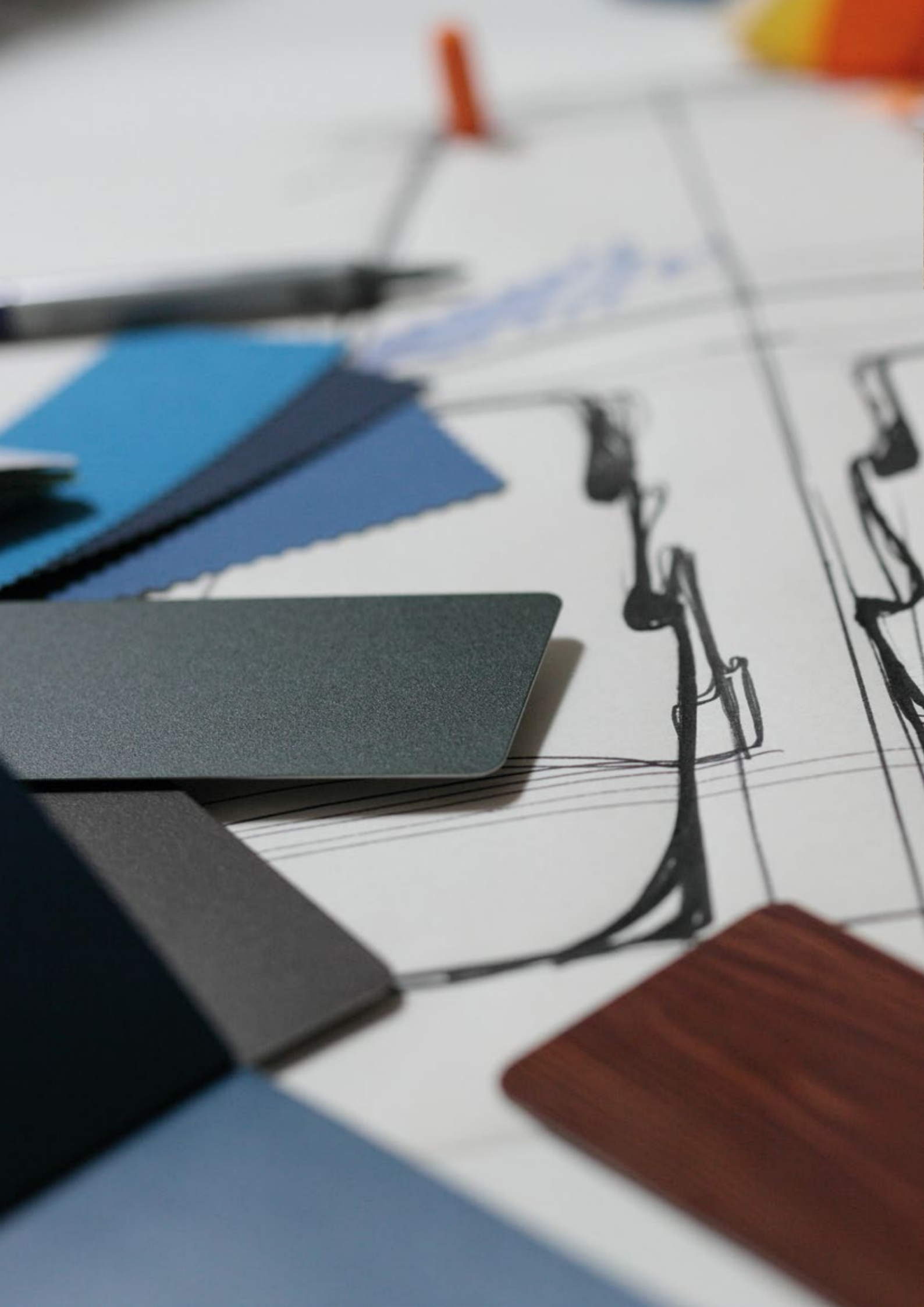

materials

Lo **studio e la sperimentazione** si innalzano ad un livello ancora più alto, per abbracciare un campo solitamente ad appannaggio dell'interior design e che, invece, riesce a essere distintivo anche per il lighting. Un **gioco sapiente e rigoroso sotto la luce geniale dei progettisti Makris**: la ricerca e l'uso di **materiali lontani dall'idea standardizzata** di illuminazione. Nasse da pesca, pelle, tessuto fino al riutilizzo a seconda vita del cuoio (rigenerato) sono la sfida ad un **uso inventivo della materia**.

***Study and experimentation** are raised to an even higher level, to embrace a field which is usually the prerogative of interior design and which, on the other hand, also manages to be distinctive for lighting. An **intelligent and rigorous game beneath the clever light of Makris designers**: the search for and use of **materials far from the standardised idea of lighting**. Fishing creels, hides, fabric up to the recycling of leather (regenerated) are the challenge for an **inventive use of materials**.*

technology

Luce solo dove e quando serve, nella miglior soluzione possibile.

Light only where and when you want it, in the best possible solution.

DALI

Ad ogni ambiente la sua luce. Un sistema con **intelligenza distribuita che permette di differenziare le emissioni luminose in base agli scenari illuminotecnici** creando vari scenari, dinamici ed efficienti, illuminando gli oggetti in maniera efficace. L'impiego di sensori di presenza e la possibilità di sfruttare la luce diurna migliorano notevolmente la qualità dell'illuminazione e riducono il consumo energetico.

*To each environment, its own light. A system with **distributed intelligence which allows differentiation of light emissions according to technical-lighting situations creating various dynamic and efficient scenarios**, lighting objects efficiently.*

The use of motion sensors and the possibility of using day-time light considerably improve lighting quality and reduce energy consumption.

CASAMBI

Basato sulla tecnologia wireless BLE (Bluetooth Low Energy) permette di **creare e gestire autonomamente il proprio impianto di illuminazione in modalità wireless**. L'applicazione, compatibile con tutti i moderni dispositivi, riconosce e associa in automatico gli apparecchi installati senza l'utilizzo di specifiche centraline. Integrabile con sensori di luminosità e di presenza aumenta la varietà di installazione: l'ideale per ogni tipologia di spazio.

*Based on BLE (Bluetooth Low Energy) wireless technology, it allows you to **create and manage your own lighting system independently in wireless mode**. The application, compatible with all modern devices, recognises and automatically associates the installed devices without the use of specific control boxes. It can be integrated with light and motion sensors and increases installation variety: ideal for every type of space.*



Philips Hue è un sistema di **illuminazione wireless connessa che abbina efficienza energetica del led e tecnologia intuitiva** permettendo di controllare, con facilità, le luci e di creare l'atmosfera giusta per ogni momento. Si integra completamente con altri dispositivi smart non legati all'illuminazione e può essere comandato tramite voce con gli assistenti Alexa e Google. Con la sua semplicità cambia il modo di utilizzare la luce!

*Philips Hue is a connected **wireless lighting system which combines the energy efficiency of the LED and intuitive technology** allowing lights to be controlled easily and creating the right atmosphere for every moment. It integrates completely with other smart devices not linked to lighting and can be controlled by voice with Alexa and Google assistants. With its simplicity it changes the way we use light!*



Grazie a questo **sistema intelligente di diffusione audio** è possibile godere di una musica di sottofondo piacevole e rilassante. Lo speaker wireless dotato di amplificatore digitale integrato riproduce il suono grazie ad un trasmettitore Wi-Fi posto a distanza.

*Thanks to this **intelligent sound system** you can enjoy pleasant and relaxing background music. The wireless speaker with an integrated digital amplifier produces sound thanks to a Wi-Fi transmitter unit placed at a distance.*



DIMMABLE

Lampada dimmerabile è possibile regolare la potenza luminosa
Dimmable lamp with possibility of adjusting the light power



TUNABLE WHITE

Tunable white regolazione variabile della temperatura di colore
Tunable white variable adjustment of colour temperature



Comando vocale è possibile accendere o spegnere le luci con comandi vocali personalizzati
Voice control the lights can be switched on and off with customised voice commands



Sensore di presenza
Movement sensor



Z LENS M

Lente zoom lente inserita sul proiettore che permette di modificare l'angolo di apertura del fascio
Zoom lens fitted on the projector which makes it possible to modify the beam aperture angle



ON-OFF TOUCH

On/Off soft touch
On/Off soft touch

CO₂

Monitoraggio CO₂
CO₂ monitoring



CRI 100

LED CRI 100 altissima qualità della luce
CRI 100 LEDs very high light quality



SPARK

Tecnologia SPARK led specifico per esaltare i colori in modo naturale o più vivido
LED SPARK technology specific for intensifying colours in a natural or more vivid way



IRIS

IRIS LED led specifico per la massima valorizzazione dei colori
IRIS LEDs specific led for maximum valorisation of colours

quando non ho più blu, metto del rosso.

when I no longer have blue, I put red.

Pablo Picasso

30_baby
34_bea
42_bell
50_blaster
58_bolle
62_bollicina
68_ciclopica
72_claudia
76_cup
80_dart
86_e/clissi
92_fallscandle
96_flat
110_globe
114_ilios
128_kassandra
134_koal
138_lady
142_malibu
148_moses
154_numa
162_orbital
166_pagoda
170_pinocchio
174_spektre
178_sphera
182_tita
188_trieste
192_venezia
196_wayd

sospensione *suspension*

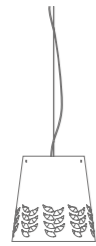

32_baby

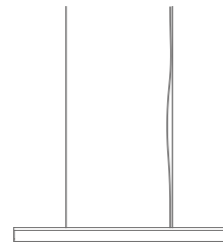

38_bea

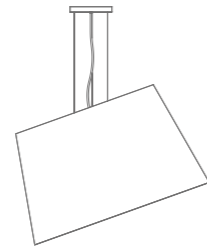

44_bell

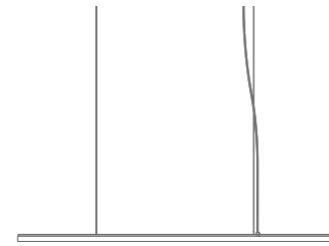

52_blaster



124_ilios s



130_kassandra



136_koal

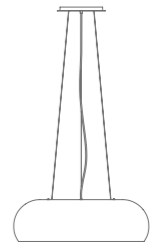

140_lady

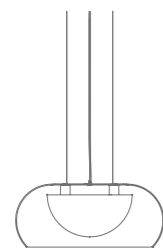

64_bollicina



70_ciclopica



74_claudia



78_cup



144_malibu

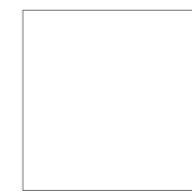

156_numa

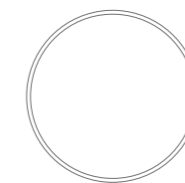

158_numa t

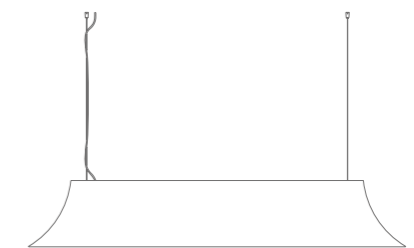

168_pagoda

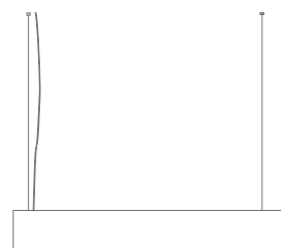

82_dart

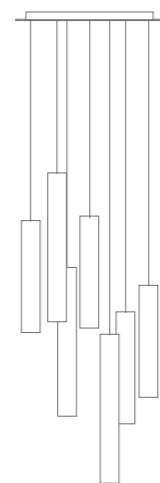

94_fallscandle



100_flat s

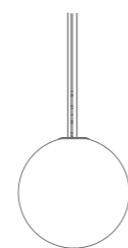

112_globe



172_pinocchio

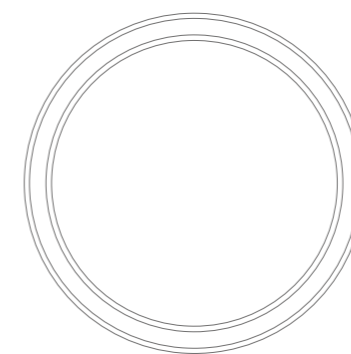

176_spektre

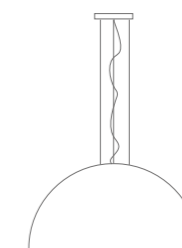

180_sphera

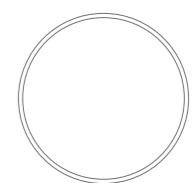

184_tita

parete wall



54_blastar wall



66_bollicina wall



104_flat p



190_trieste



194_venezia

soffitto ceiling



60_bolle

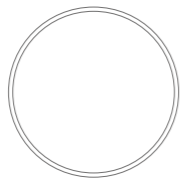

186_tita

piantana floor



102_flat t

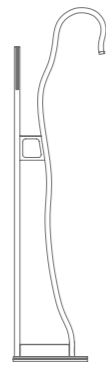

152_moses



198_wayd

proiettore projector

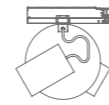

88_e/clissi



120_ilios p



122_ilios up

incasso recessed



118_ilios i

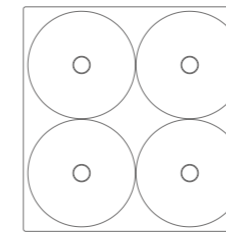

164_orbital

baby

Baby è una lampada a sospensione creativa, caratterizzata da una grafica intagliata sul corpo della lampada, in grado di regalare particolari giochi di luce. Divertente e tecnologica, è l'ideale per tutti gli spazi indoor, grazie alla completa personalizzazione dell'estetica.

Baby is a creative pendant light, featuring a decorative incision on its body which gives attractive light effects. With a looks that is totally customisable, it is fun and technological and ideal for all indoor spaces.





baby

Sospensione con corpo in alluminio lucidato a specchio. Disponibile in versione dimmerabile, è integrabile con la tecnologia CASAMBI.

A pendant light with mirrored aluminum structure. Available in a dimmable version, it can be combined with CASAMBI technology.

baby sospensione *suspension*

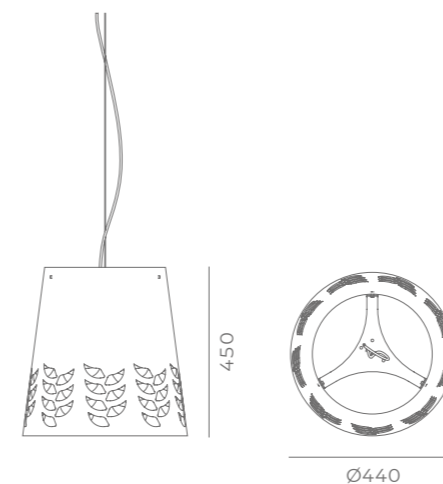

Fonte luminosa
Light source

Temperatura colore
Colour temperature

Flusso luminoso
Luminous flux

Finiture
Finishing

20 W (E27)

2700 K
4000 K

2500 lm

specchio
mirror



Corpo alluminio
Body aluminum

IP20

Symphonica
SMART SOUND

DIMMABLE

integrabile con HUE e CASAMBI
It can be combined with HUE and CASAMBI

grafica personalizzabile su richiesta
custom graphic design on request

bea

Bea è materia luminosa in cui luce e buio sono contrapposti e uniti allo stesso tempo. Nel corpo superiore vi è la luce, mentre in quello inferiore, monolitico e compatto, vi è il buio dal quale sgorga la luce stessa. Quella di Bea è una "semplicità pensata" alla quale si aggiunge una grande flessibilità che la rendono adatta ad ogni tipo di ambiente, dall'ufficio alla casa.

Bea is a luminous structure in which light and darkness contrast and unite at the same time. In the upper body there is light, while in the monolithic, compact lower part, there is darkness from which light itself springs. Bea typifies a "well-thought-out simplicity" combined with great flexibility which makes it suited to every type of environment, from offices to homes.



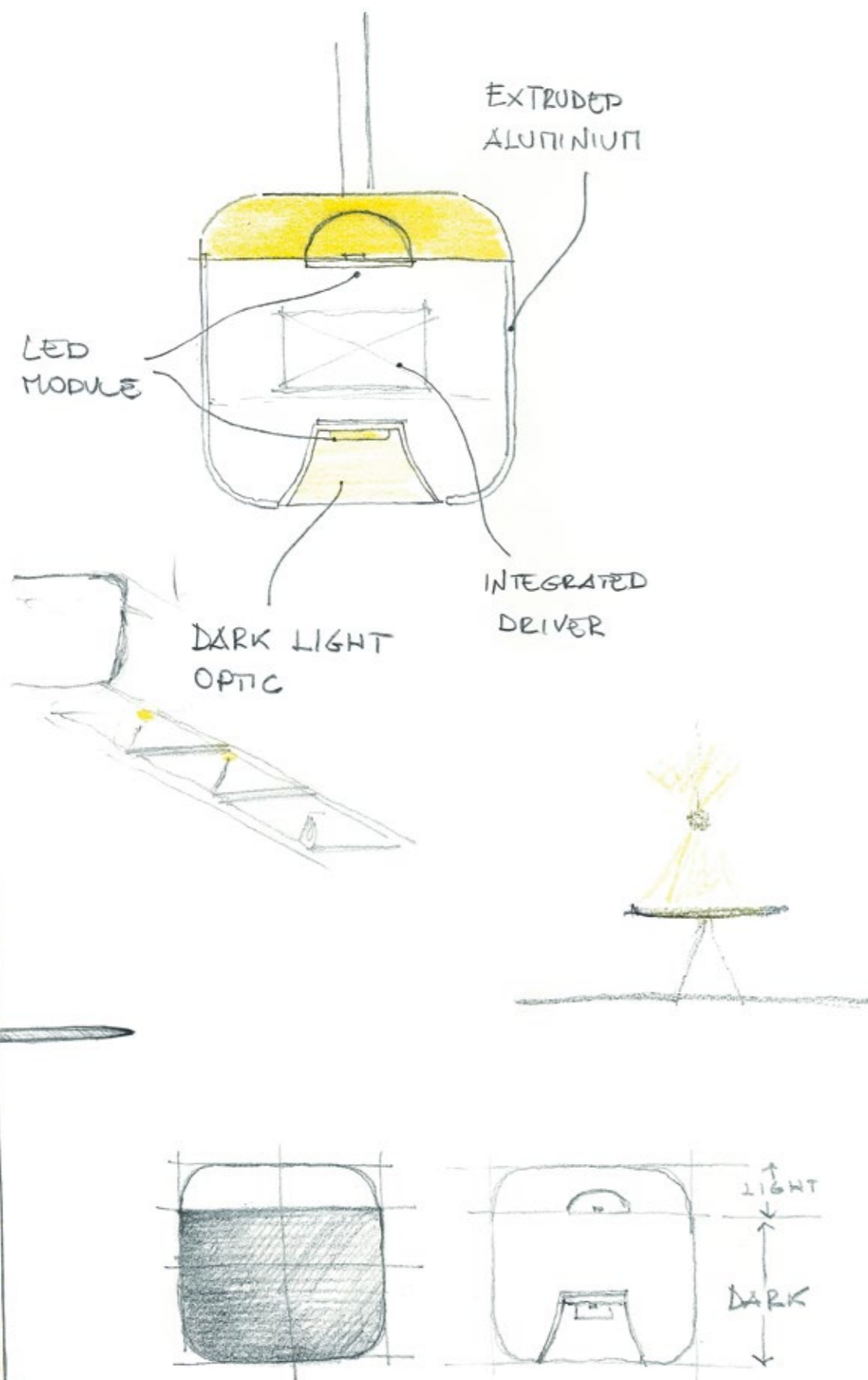

luce discreta

discreet light

Gli opposti. La luce e il buio.

La materia luminosa, la presenza, ferita nella sua parte centrale dalla quale sgorga la luce. Il corpo inferiore, l'assenza, scuro, monolitico e compatto che conserva il cuore tecnologico della lampada. La B si specchia e trova nel suo riflesso una E di congiunzione con la A, due opposti che si attraggono. BEA.

Opposites. Light and Dark.

Luminous material - the presence - wounded in its centre where the light flows out. The lower body - the absence - dark, monolithic and compact, which preserves the technological heart of the lamp. The B reflects and finds its reflection in an E that joins with A, two opposites that attract each other. BEA.

BEA

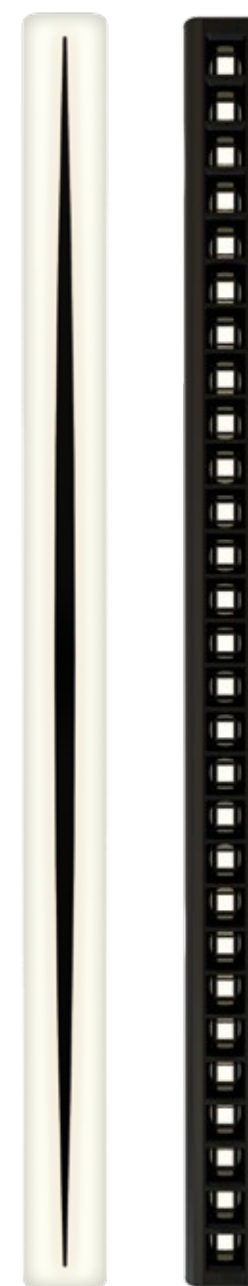



bea

design **Andrea Benedetto**

Apparecchio a sospensione raffinato ed essenziale, si compone di due elementi distinti: la parte inferiore è un corpo in estruso di alluminio che accoglie il cuore tecnologico con ottiche dark light e driver integrati, che ne consentono la dimmerazione e il tunable white; la parte superiore, con luce tunable white e dimmerabile, rappresenta l'elemento diffusivo, un taglio scuro da cui si sprigiona la luce, ammorbidendo l'ambiente e vestendolo di un'illuminazione soffice, evitando spiacevoli contrasti di luminosità. Disponibile con modalità DALI, CASAMBI.

A sophisticated and clean-cut pendant light, it is composed of two distinct elements: the lower part is in extruded aluminium containing the technological core with integrated dark light optics and driver which allow dimming and tunable white.

The top, with tunable white and dimmable light, is the diffusion element, a dark slit from which light is released, softening the space and cladding it in a soft light, preventing unpleasant luminance contrasts. Available with DALI and CASAMBI technology.

bea

sospensione *suspension*



Fonte luminosa <i>Light source</i>	Lenti <i>Lens</i>	Temperatura colore <i>Colour temperature</i>	Flusso luminoso <i>Luminous flux</i>	Finiture <i>Finishing</i>
indiretta/uplight 24 W	-	3000 K	da/from 4150 lm a/to 4350 lm	nero opaco <i>matt black</i>
diretta/downlight 23 W	50° 80°	4000 K	da/from 4200 lm a/to 4400 lm	bianco opaco <i>matt white</i>

Corpo estruso di alluminio verniciato a polvere epossidica **Diffusore** superiore in PMMA satinato
Body extruded aluminium epoxy powder coated **Diffuser** PMMA opal

IP20

DALI

CASAMBI







bell

Bell è un apparecchio a sospensione in grado di vivere singolo o accoppiato per composizioni scenografiche. La forma tronco-conica sintetizza quella di una campana e l'orientamento suggerisce l'idea del dinamismo. Le sue grandi dimensioni permettono di interpretare in maniera inconsueta gli ambienti domestici, ma si adattano perfettamente anche ai grandi spazi pubblici.

Bell is a pendant light which can be installed on its own or together with others to create spectacular compositions. The conical trunk-like shape is reminiscent of a bell and its orientation suggests the idea of dynamism. Its large dimensions allow it to give unusual interpretations to domestic spaces but it is also perfectly suited to large public areas.

Sospensione con Ø 1000 mm. Una luce d'impatto e mai abbagliante, grazie al diffusore opale, ideale per ambienti indoor anche di grandi dimensioni. Il corpo in alluminio è rivestito in materiale polimerico ad altissima resistenza; l'emissione luminosa è in grado di raggiungere 10600 lm. Bell è integrabile con le migliori tecnologie di gestione e controllo.

A pendant light with a diameter of 1000 mm. A light which impacts but never dazzles, thanks to the opal diffuser, ideal for even large-scale indoor spaces. The aluminium body is covered in a highly resistant polymeric material: light output can reach as much as 10600 lm. Bell can be combined with the best management and control technologies.



bell

design Area-17

bell

sospensione *suspension*

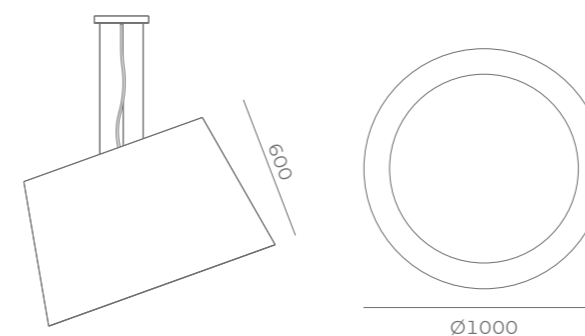

Fonte luminosa <i>Light source</i>	Temperatura colore <i>Colour temperature</i>	Flusso luminoso <i>Luminous flux</i>	Finiture <i>Finishing</i>
53 W	3000 K 4000 K	da/from 10100 lm a/to 10600 lm	in rovere - out rame in oak - out copper in rame - out rovere in copper - out oak RAL standard standard RAL

Corpo alluminio, rivestimento in materiale polimerico ad alta resistenza texturizzato **Diffusore** PMMA opale
Body aluminium cone with high strenght polymer cover **Diffuser** opal PMMA





bell è l'istantanea
di un movimento.

bell is the instantaneous moment of a movement.

Area-17





blaster

Blaster, disponibile per applicazioni a sospensione e a parete, è leggero e geometrico. Nato per generare forme continue luminose. Il corpo illuminante può dare vita ad infinite strutture di luce, lineari o circolari, sempre in dialogo con l'ambiente che le ospita.

Blaster, available for suspended and wall applications, is a light geometrical luminaire. Created to generate continuous luminous shapes. The lighting body can create infinite linear or circular light structures, dialoguing constantly with the space where it is installed.

blaster



Apparecchio in grado di generare, un'elevata uniformità luminosa quando acceso, grazie al corpo diffondente in PMMA, e una totale trasparenza ad elemento spento.

Una presenza minima che, grazie all'inserimento del LED nella parte alta del corpo, permette di emettere una luce fino a 270° generando una luce ancora più avvolgente.

Luminaire able to generate a high uniformity of light when switched on, thanks to the PMMA diffusing body, and a total transparency when the element is switched off.

A minimum presence that, thanks to the insertion of the LED in the upper part of the body, allows to emit a light up to 270° generating an even more enveloping light.

blaster

sospensione *suspension*

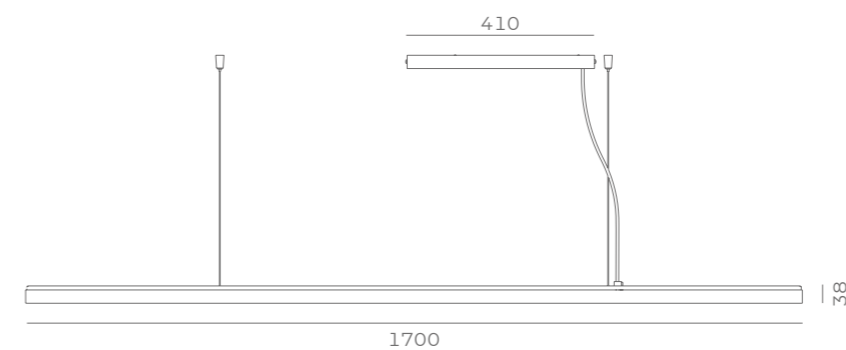

Fonte luminosa
Light source

Temperatura colore
Colour temperature

Flusso luminoso
Luminous flux

Finiture
Finishing

30 W

3000 K
4000 K

da/from
5000 lm
a/to
5300 lm

PMMA bianco satinato
PMMA satin white



Diffusore PMMA satinato
Diffuser satin PMMA

IP20

DALI

CASAMBI



Apparecchio da parete in grado di generare un'elevata uniformità luminosa quando acceso, grazie al corpo diffondente in PMMA, e una totale trasparenza ad elemento spento.

Una presenza minima che, grazie all'inserimento del LED nella parte alta del corpo, permette di emettere una luce fino a 270° generando una luce ancora più avvolgente.

A light for wall application able to generate a high uniformity of light when switched on, thanks to the PMMA diffusing body, and a total transparency when the element is switched off.

A minimum presence that, thanks to the insertion of the LED in the upper part of the body, allows to emit a light up to 270° generating an even more enveloping light.

blaster wall



blaster parete wall

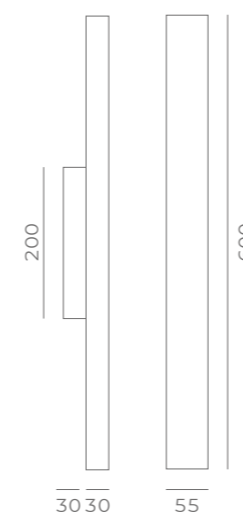

Fonte luminosa
Light source

15 W

Temperatura colore
Colour temperature

3000 K
4000 K

Flusso luminoso
Luminous flux

da/from
2000 lm
a/to
2200 lm

Finiture
Finishing

PMMA bianco satinato
PMMA satin white



Diffusore PMMA satinato
Diffuser satin PMMA

IP20

DALI

CASAMBI





master
blaster



bolle

Una bolla che genera una luce morbida e confortevole. Dotato di un anello in alluminio personalizzabile in differenti colori, dona personalità ed eleganza all'apparecchio. Bolle è perfetto per essere installato nel settore hospitality, all'interno di aree commerciali e negozi.

A "bubble" that creates a soft comfortable light. It has an aluminium ring that can be customised in different colours giving the luminaire a touch of personality and elegance. Bolle is the perfect solution for the hospitality sector, or internally in stores and shopping centres.





bolle

Bolle è un plafone elegante e dalla forte personalità. Il diffusore è in PMMA per un'ottima illuminazione diffusa confortevole. La lampada è realizzabile in differenti colori e in tre dimensioni ed è disponibile in versione dimmerabile ed integrabile con tecnologia DALI.

Bolle is an elegant ceiling fixture with a strong personality. The diffuser in PMMA guarantees excellent and comfortable diffused lighting. The fixture is made in different colours and in three different sizes and it is available in a dimmable version and can be integrated with DALI technology.

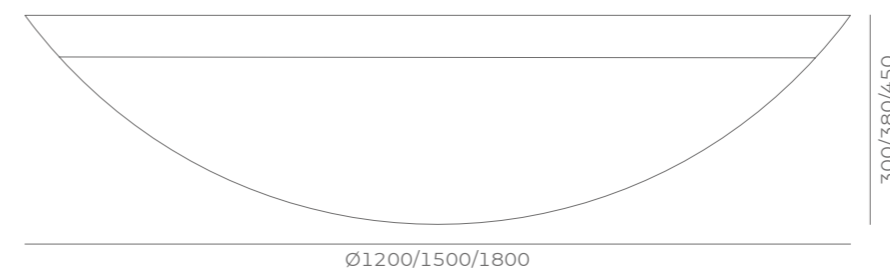
bolle
soffitto ceiling



Fonte luminosa Light source	Temperatura colore Colour temperature	Flusso luminoso Luminous flux	Finiture Finishing
da/from 64 W	3000 K	da/from 10800 lm	alluminio verniciato coated aluminium 
a/to 193 W	4000 K	a/to 31200 lm	

Corpo alluminio verniciato **Diffusore** PMMA opale
Body coated aluminium **Diffuser** opal PMMA

IP20

DALI



bollicina

Una bolla trasparente che ne racchiude un'altra al suo interno, cuore luminoso e reale diffusore della luce. Il corpo di Bollicina è sospeso attraverso tre cavi in acciaio, fissati al soffitto grazie ad una cassa di ancoraggio che ospita al suo interno una tecnologia interattiva, diffusori audio e sensore di presenza. Disponibile anche per applicazioni a parete.

A transparent bubble enclosing a smaller bubble, a luminous heart and veritable light diffuser. Bollicina's body is suspended by three steel cables, attached to the ceiling by a fixture box containing interactive technology, sound diffusers and a movement sensor. Also available for wall applications.



bollicina

design **Matteo Piedi**

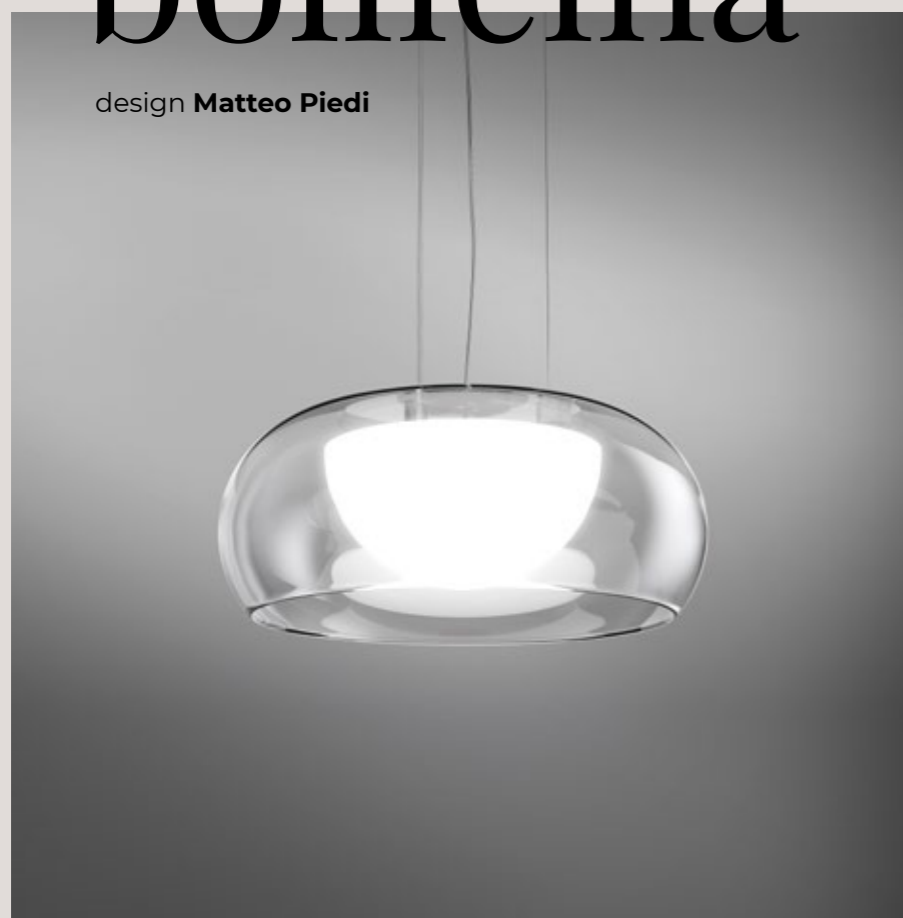

La luce emessa, con temperatura colore di 3000 K e 4000 K, è diffusa e accogliente, grazie al diffusore in PMMA opale che caratterizza la bolla centrale dell'apparecchio. Integrabile con le tecnologie CASAMBI e DALI.

The emitted light has a colour temperature of 3000 K and 4000 K, it is diffused and welcoming thanks to the diffuser in opal PMMA which is a feature of the central bubble of the light. It can be combined with CASAMBI and DALI technologies.

bollicina

sospensione *suspension*

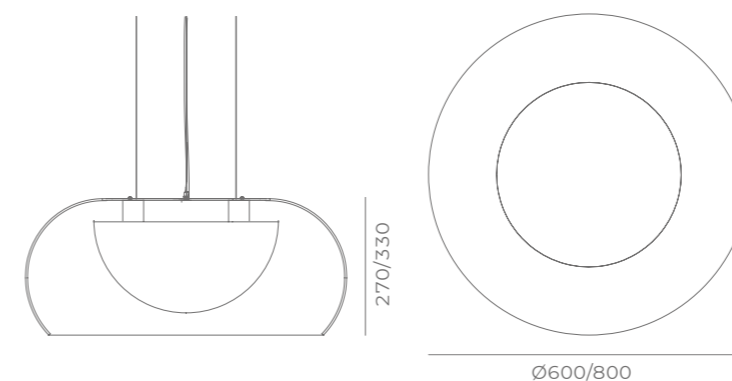



Fonte luminosa
Light source

Temperatura colore
Colour temperature

Flusso luminoso
Luminous flux

Finiture
Finishing

31 W	3000 K	da/from 4900 lm	in bianco opale - out trasparente <i>in opal white - out transparent</i>	
	4000 K	a/to 5000 lm	in bianco opale - out fumé grigio <i>in opal white - out smoked gray</i>	
			in bianco opale - out fumé marrone <i>in opal white - out smoked brown</i>	

Corpo PMMA trasparente **Diffusore** PMMA opale
Body transparent PMMA **Diffuser** opal PMMA

IP20

DALI

CASAMBI

Symphonica
SMART SOUND



Un apparecchio a parete in grado di generare una luce diffusa e accogliente, grazie al diffusore in PMMA opale che caratterizza la bolla centrale dell'apparecchio. Integrabile con le tecnologie CASAMBI e DALI.

Wall luminaire that can be able to generate a diffused and welcoming light thanks to the diffuser in opal PMMA which is a feature of the central bubble of the light. It can be combined with CASAMBI and DALI technologies.

bollicina wall

design **Matteo Piedi**



bollicina parete wall

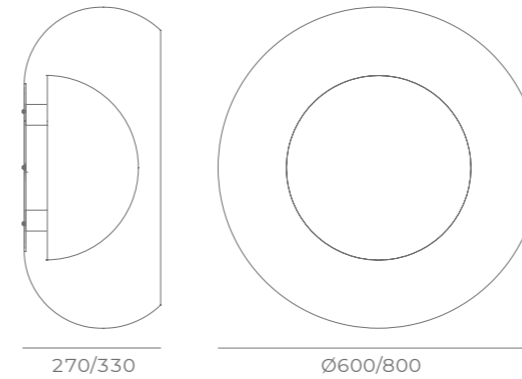

Fonte
luminosa
Light source

Temperatura colore
Colour
temperature

Flusso
luminoso
Luminous flux

Finiture
Finishing

31 W	3000 K 4000 K	da/from 4900 lm a/to 5000 lm	<p>in bianco opale - out trasparente <i>in opal white - out transparent</i></p> <p>in bianco opale - out fumé grigio <i>in opal white - out smoked gray</i></p> <p>in bianco opale - out fumé marrone <i>in opal white - out smoked brown</i></p>
------	------------------	---	---

Corpo PMMA trasparente **Diffusore** PMMA opale
Body transparent PMMA **Diffuser** opal PMMA

IP20

DALI

CASAMBI



ciclopica

Un cilindro di luce sospeso estremamente minimalista. Il design di Ciclopica è sobrio, essenziale, perfetto: un apparecchio che si trasforma letteralmente in un occhio di luce in grado di regalare atmosfera ad ogni ambiente.

An extremely minimalist pendant light cylinder. Ciclopica has a simple, clean-cut, perfect design: a light which literally changes into an eye of light able to create an atmosphere for every space.



ciclopica

Apparecchio a sospensione in alluminio verniciato e personalizzabile in varie finiture. Ideale per ambienti interni, Ciclopica è un cilindro con Ø 120 mm. Disponibile in versione dimmerabile e integrabile con tecnologie HUE, CASAMBI, DALI.

A painted aluminium pendant light which can be customised in a variety of finishes. Ideal for interior spaces, Ciclopica is a cylinder with a diameter of 120 mm. Available in dimmable version and it can be combined with HUE, CASAMBI and DALI technologies.

ciclopica

sospensione *suspension*

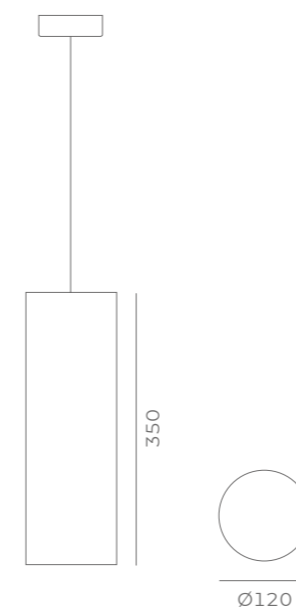

Fonte luminosa <i>Light source</i>	Temperatura colore <i>Colour temperature</i>	Flusso luminoso <i>Luminous flux</i>	Finiture <i>Finishing</i>
24 W 9 W (E27)	3000 K EWarmHD	da/from 760 lm a/to 3000 lm	alluminio verniciato opaco  <i>matt coated aluminum</i>

Corpo alluminio verniciato
Body *coated aluminium*

IP20

DALI



integrabile con HUE e CASAMBI
It can be combined with HUE and CASAMBI

claudia

Claudia è un richiamo agli anni '70, con un vago accenno al gusto orientale. Una sospensione perfetta per gli spazi collettivi e totalmente personalizzabile nell'abbinamento delle finiture.

Claudia is a flash-back to the Seventies with a vague hint of oriental taste. A pendant light perfect for communal areas and totally customisable in its combination of finishes.



claudia



Claudia è una lampada che arreda, grazie alla possibilità di personalizzazione della finitura del PMMA mono o bicolore. Disponibile con tecnologia CASAMBI e dimmerabile, Claudia è l'ideale per l'illuminazione di ambienti di lavoro e aree comuni.

Claudia is a luminaire that furnishes, thanks to the possibility of customizing its mono or two-coloured PMMA finish. Available with CASAMBI and dimmable technology, Claudia is ideal for lighting work environments and communal areas.

claudia sospensione *suspension*

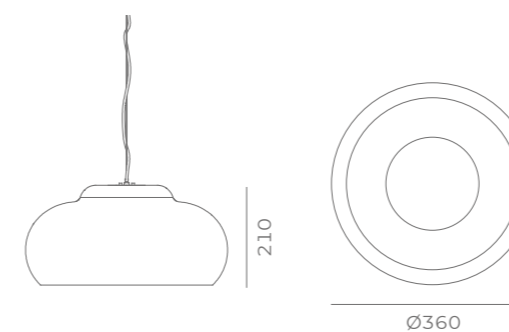



Fonte luminosa
Light source

Temperatura colore
Colour temperature

Flusso luminoso
Luminous flux

Finiture
Finishing

20 W (E27)	2700 K 4000 K	2500 lm	<p>in bianco - out nero <i>in white - out black</i> </p> <p>in rosso - out nero <i>in red - out black</i> </p> <p>in bianco - out rosso <i>in white - out red</i> </p> <p>PMMA bicolore lucido <i>polished two-coloured PMMA</i> </p>
------------	------------------	---------	--

Corpo PMMA bicolore
Body two-coloured PMMA

IP20



integrabile con HUE e CASAMBI
It can be combined with HUE and CASAMBI



Cup

Cup è una sospensione dalle linee eleganti in vetro e rame. Un gioco di forma e atmosfera evocato da design e materiali: la luce è precisa sulla superficie da illuminare, e, allo stesso tempo, diffusa verso l'alto grazie al vetro trasparente che aggiunge un gioco di luce e atmosfera all'ambiente.

Cup is a pendant light with elegant lines in glass and copper. A play of shape and atmosphere conjured up by design and materials. The light is precise on the surface to be lit, and, at the same time, diffused upwards thanks to the transparent light which adds a play of light and atmosphere to the environment.

cup





Cup è una sospensione ideale per interni, caratterizzata da un corpo in vetro trasparente e da cavo e portalamпада in rame. L'eleganza è al centro del concept di questo apparecchio dal sapore vintage, a cui si aggiunge la tecnologia della sorgente LED con potenza 6 W e output luminoso di 800 lm.

Cup is an ideal pendant light for interiors, featuring a structure in transparent glass and a cable and lamp-holder in copper. Elegance is at the centre of the concept of this light with a vintage flavour, supported by 6 W LED source technology and a light output of 800 lm.

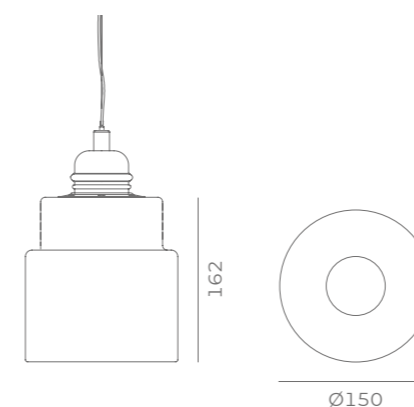
cup sospensione *suspension*



Fonte luminosa <i>Light source</i>	Temperatura colore <i>Colour temperature</i>	Flusso luminoso <i>Luminous flux</i>	Finiture <i>Finishing</i>
6 W (E27)	2700 K	800 lm	rame* copper*  vetro trasparente transparent glass 

Corpo vetro trasparente **Portalamпада** metallo
Body transparent glass **Lamp holder** metal

*La finitura rame potrebbe cambiare colore nel tempo a causa del naturale processo di ossidazione. A differenti lotti di produzione potrebbe corrispondere una variazione di colore sulla finitura rame. Fortemente sconsigliato l'uso della finitura rame in zone con presenza di nebbia salina.

*Copper finish could change colour over time because of natural oxidation. Colour variations may occur between copper surfaces originating from different production batches. Use of copper surface in sea spray affected areas is strongly discouraged.

IP20



integrabile con HUE e CASAMBI
It can be combined with HUE and CASAMBI



dart

Sospensione dalla forma lineare che illumina e genera l'atmosfera perfetta per ogni ambiente indoor. Dart è disponibile in una doppia versione, con emissione singola o doppia, ed è personalizzabile attraverso molteplici possibilità di colore del rivestimento interno. La tecnologia è all'essenza, grazie alla completa integrabilità dell'apparecchio con le tecnologie PHILIPS HUE, DALI, CASAMBI.

A pendant light with a linear shape which lights and generates a perfect atmosphere for every indoor space. Dart is available in a double version, with single or double output and can be customised with a wide range of possible colours for the interior part. Technology is its essence because the light can be combined with PHILIPS HUE, DALI, CASAMBI.





dart

Dart ha un corpo in PMMA colorato rivestito internamente con pellicola polimerica personalizzabile in differenti colori. Una sospensione discreta e installabile in ogni ambiente indoor, anche grazie alle dimensioni: lo spessore, infatti, è di soli 65 mm. La scelta ideale per illuminare gli ambienti con la minima invasività e creare atmosfere perfette.

Dart has a body in coloured PMMA clad internally with a customisable polymeric film available in different colours. A discrete pendant light which can be installed in any space, thanks also to its dimensions: in fact, it is only 65 mm thick. The ideal choice for lighting spaces where minimalism is required and for creating perfect atmospheres.

dart sospensione *suspension*



Fonte luminosa <i>Light source</i>	Temperatura colore <i>Colour temperature</i>	Flusso luminoso <i>Luminous flux</i>	Finiture <i>Finishing</i>
35 W	3000 K 4000 K	da/from 5900 lm a/to 6000 lm	in arancione lucido - out nero opaco in polished orange - out matt black
indiretta/uplight 35 W system diretta/downlight 40 W system	RGBW (HUE)	indiretta/uplight 2700 lm diretta/downlight 3000 lm	in nero opaco - out nero lucido in matt black - out polished black

Corpo PMMA colorato, pellicola polimerica
Body colored PMMA, polymeric film

IP20

DALI



lunghezza personalizzabile su richiesta
bespoke linear led profile





e/clissi

E/clissi è un proiettore a binario con possibilità di installazione di faretto singoli o doppi tramite un sistema magnetico integrato, per un perfetto posizionamento dei proiettori. Disponibile con finitura bianca e nera o personalizzabile, è installabile in ambienti interni che necessitano di una luce direzionata, come luoghi di lavoro open space, bar e ristoranti ma anche strutture museali o espositive e ambienti living di varia tipologia.

E/clissi is a track projector on which single or double spotlights can be installed using an integrated magnetic system, for positioning the projectors perfectly.

Available with a black, white or customisable finish, it can be installed in interiors requiring a targeted light, such as open space work areas, bars and restaurants but also museums and exhibition centres and various types of living spaces.

e/clissi

design **Alessandro Canepa**

Il proiettore E/clissi è fissato ad un disco di supporto di 20cm di diametro ed è interamente ruotabile a seconda delle esigenze, così da schermare la luce emessa dai faretti in base al posizionamento, per una massima efficienza e direzionabilità della luce. Disponibile con sorgente LED Spark neutral o cold e integrabile con tecnologia DALI e CASAMBI.

The E/clissi projector is fixed to a 200 mm – diameter supporting disk and is fully rotatable according to needs, so as to shield the light emitted from the spotlights according to their position, to give maximum light efficiency and orientation.

Available with neutral or cold Spark LED source and it can be combined with DALI and CASAMBI technologies.



e/clissi proiettore projector

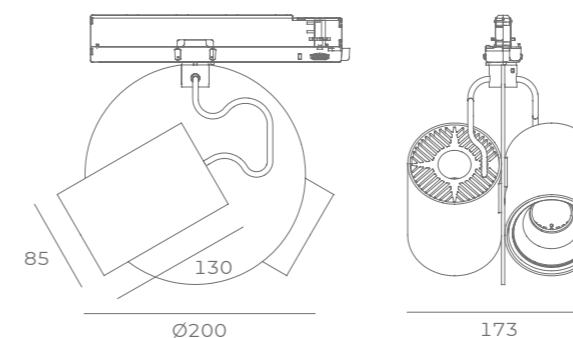

Fonte luminosa Light source	Temperatura colore Colour temperature	Riflettori Reflectors	Flusso luminoso Luminous flux	Finiture Finishing
da/from 2x13 W	3000 K	18°	da/from 2x1900 lm	nero lucido polished black ●
a/to 2x15 W	4000 K	28°	a/to 2x2600 lm	bianco lucido polished white ○
	spark neutral	55°		
	spark cold	70°		
		versione lens/ lens version 13°		

Corpo alluminio verniciato a polvere epossidica
Body aluminium epoxy powder coated

IP20 **DALI** **CASAMBI** **Z LENS • M** **SPARK**

e/clissi, in cui sole e luna si fondono.

e/clissi, in which sun and moon merge.

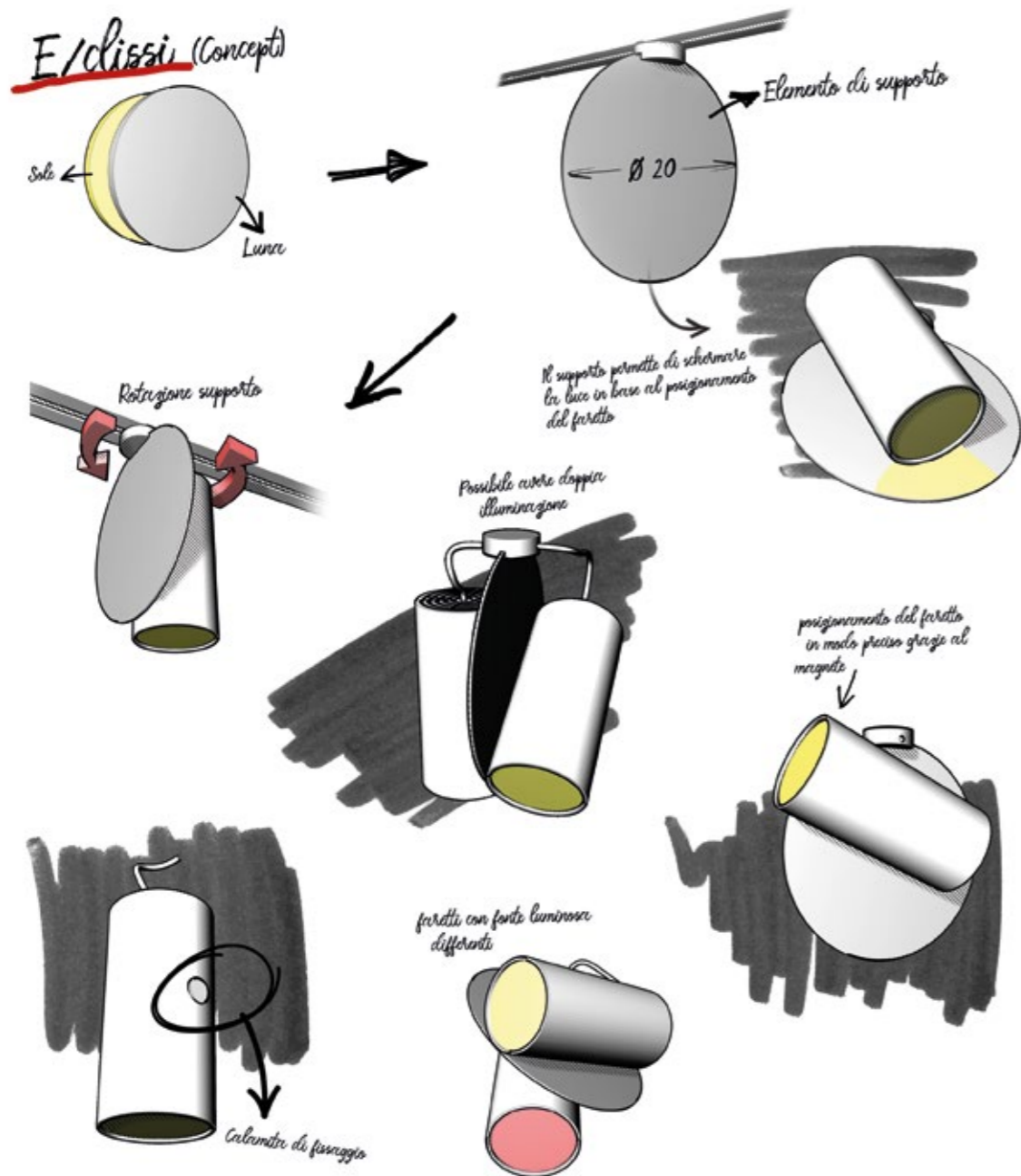

fallscandle

Una sospensione tradotta in una pioggia di elementi luminosi. Fallscandle è composta da cilindri sospesi posti a differenti altezze, per un effetto a cascata che non passa inosservato. Un'illuminazione puntuale, un'eleganza innata ed un senso di movimento unici, che non ne trascurano, allo stesso tempo, l'efficienza.

A pendant light translated into a shower of luminous elements. Fallscandle is composed of cylinders suspended at different heights for a waterfall effect, which cannot help but be noticed. A unique, accurate illumination, an innate elegance and a sense of movement which, at the same time, does not forfeit efficiency.



fallscandle



Fallscadle è una sospensione elegante e preziosa caratterizzata da singoli elementi sospesi con corpo metallico oro e bronzo spazzolato e PMMA satinato. L'apparecchio è dotato di sette sorgenti LED da 10 W di potenza ognuna ed è dimmerabile, per effetti luminosi di infinita bellezza.

Fallscandle is an elegant, precious pendant light characterised by individual suspended elements with a metallic gold, brushed bronze and satin-finished PMMA body. The light is fitted with seven 10 W LED sources each and can be combined with dimmable technologies, for infinitely beautiful lighting effects.

fallscandle

sospensione *suspension*

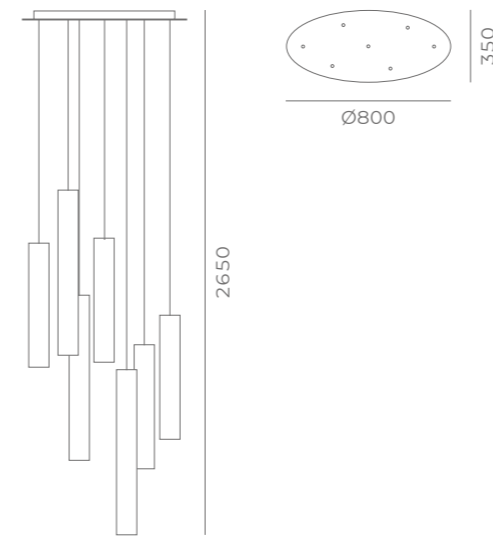

Fonte luminosa
Light source

Temperatura colore
Colour temperature

Flusso luminoso
Luminous flux

Finiture
Finishing

Fonte luminosa <i>Light source</i>	Temperatura colore <i>Colour temperature</i>	Flusso luminoso <i>Luminous flux</i>	Finiture <i>Finishing</i>
7x14 W (E27)	2700 K	7x1500 lm	2x oro spazzolato 2x brushed gold  3x PMMA satinato 3x satin PMMA  2x bronzo spazzolato 2x brushed bronze 

Corpo alluminio spazzolato e verniciato, PMMA satinato
Body painted and brushed aluminium, satin PMMA

IP20



flat

Famiglia di apparecchi disponibili in tre varianti P, S, T, rispettivamente per applicazioni a parete, sospensione e terra; l'ideale per l'illuminazione uffici o abitazioni.

La lampada incorpora le migliori tecnologie avanzate come la tecnologia PHILIPS HUE che, con il semplice utilizzo della HUE App installata su smart device, consente di regolare l'intensità e la tonalità di colore della luce personalizzando la propria illuminazione e generando l'atmosfera giusta in ogni momento.

A family of lighting devices available in three versions P, S, T, respectively for wall-mounted, pendant and floor applications, ideal for lighting offices or homes.

The lamp incorporates the best advanced technologies such as PHILIPS HUE which, with the simple use of the HUE App installed on a smart device, allows the intensity and shades of colour of the light to be adjusted, customising its own lighting and generating the right atmosphere for every moment.



luce e colore

light and color



Esperienza di luce e colore. Un design con personalità. La lampada incorpora la tecnologia **PHILIPS HUE**. Con il semplice utilizzo della HUE App installata su smart device è possibile regolare l'**intensità** e la **tonalità** di **colore** della luce personalizzando la propria illuminazione e generando l'atmosfera giusta in ogni momento. Ideale per l'illuminazione di un ambiente di ufficio o di qualsiasi altra stanza.

*Light and colour experience. Design with personality. The lamp incorporates **PHILIPS HUE** technology and with the simple use of the HUE App installed on smart devices, it is possible to adjust both the light **intensity** and **colour shade**.*

This customises the lighting and generates the right atmosphere. Ideal for lighting an office environment or any other room.

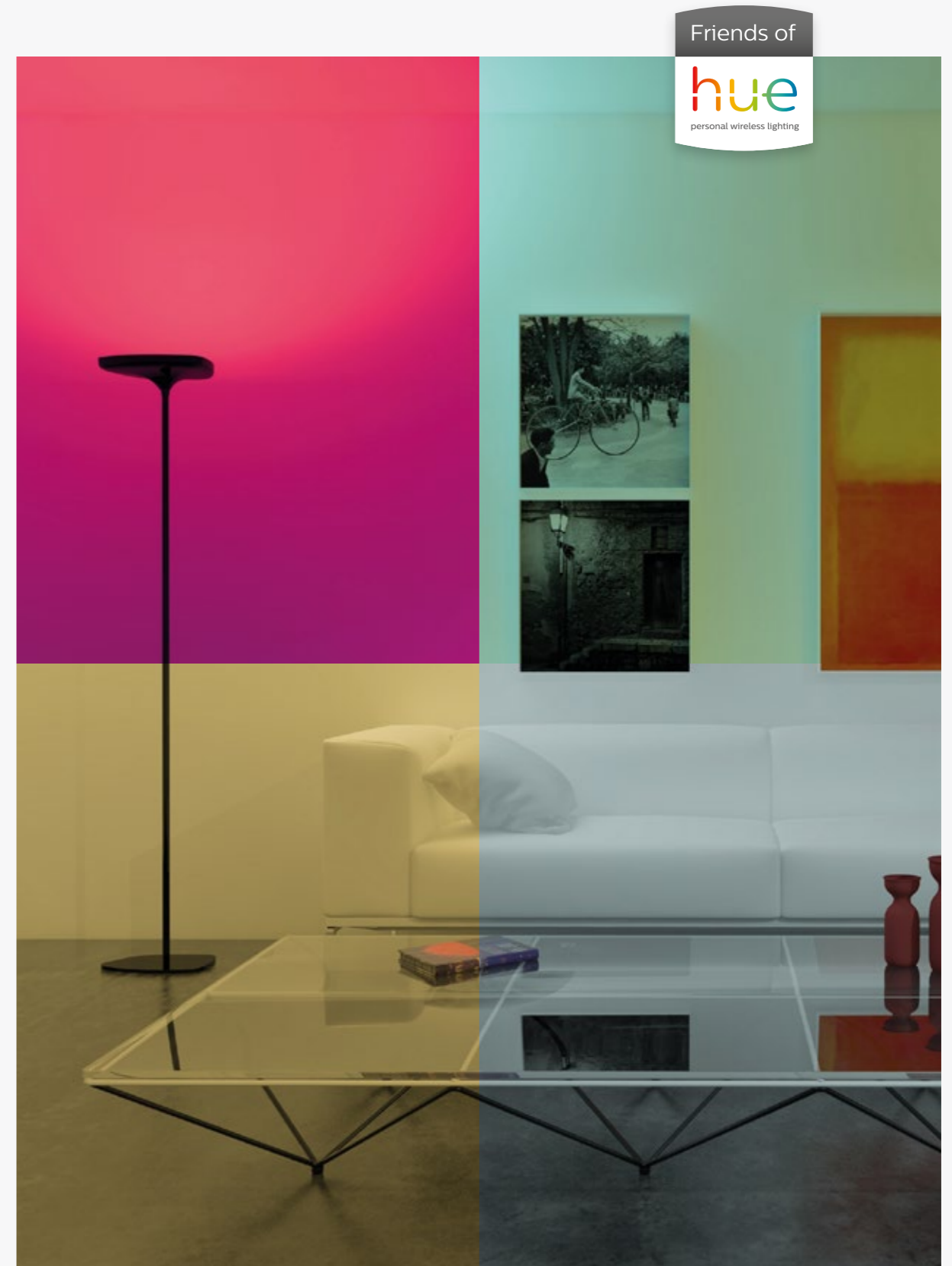
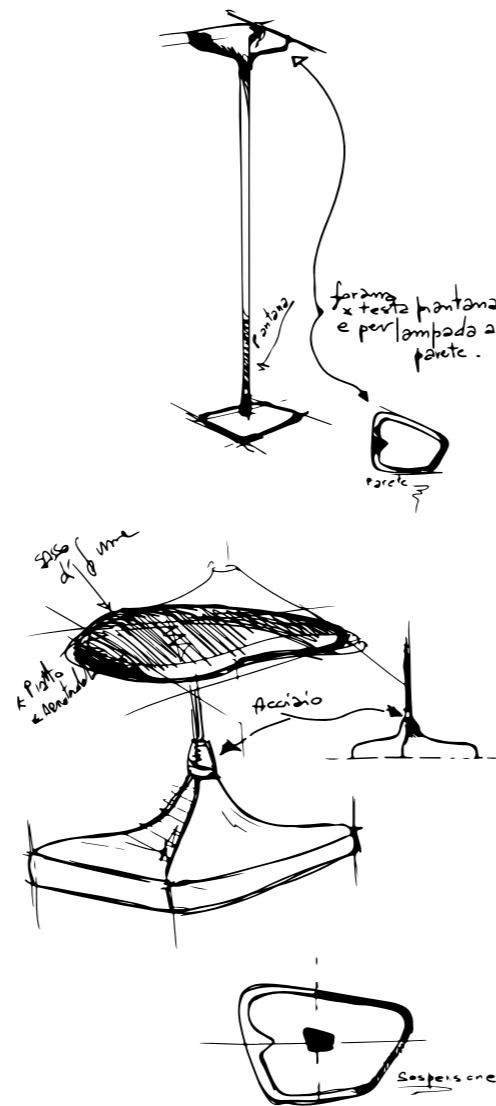



flat s

design **Gianpietro Tonetti**

Apparecchio a sospensione con struttura in PMMA lucido e schermo satinato pensato per una massima diffusione della luce. Un design che richiama la forma di una pietra levigata e resta sospeso nello spazio, per un apparecchio con sorgente LED disponibile in versione white 3000 K - 4000 K o RGBW.

A pendant light with a glossy PMMA structure and satin-finished screen designed for maximum light diffusion. A design which is reminiscent of the shape of the smoothed stone and remains suspended in space, for a device with LED source available in white 3000 K - 4000 K or RGBW version.

flat

sospensione *suspension*

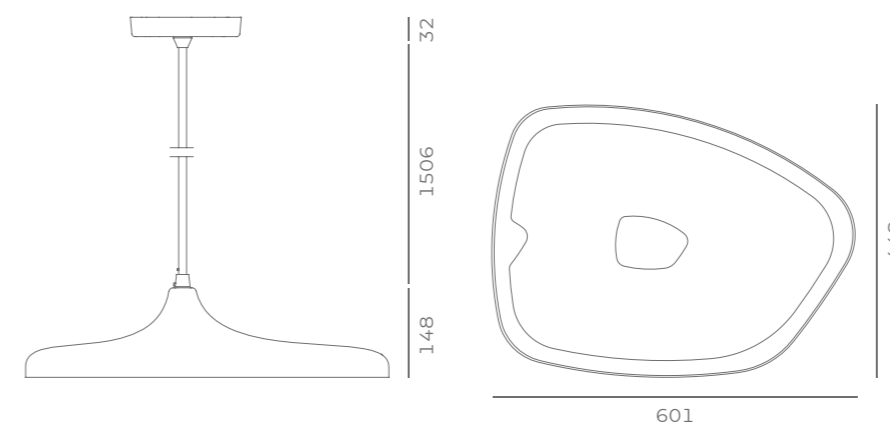

Fonte luminosa <i>Light source</i>	Temperatura colore <i>Colour temperature</i>	Flusso luminoso <i>Luminous flux</i>	Finiture <i>Finishing</i>
da/from 39 W	3000 K	4000 lm	nero lucido <i>polished black</i>
a/to 43 W	4000 K		bianco lucido <i>polished white</i>
40 W	RGBW (HUE)	3000 lm	

Corpo PMMA lucido **Diffusore** PMMA satinato
Body polished PMMA **Diffuser** satin PMMA

IP20



Lampada da terra che cresce verso l'alto fino a 1825 mm e diventa elemento d'arredo. Luce e design si fondono, attraverso stile ed efficienza. Schermo diffusore in PMMA satinato.

Floor light which extends upwards up to 1825 mm and becomes a furnishing element. Light and design merge, through style and efficiency. A diffuser screen in satin-finished PMMA.

flat t

design **Gianpietro Tonetti**



flat terra floor

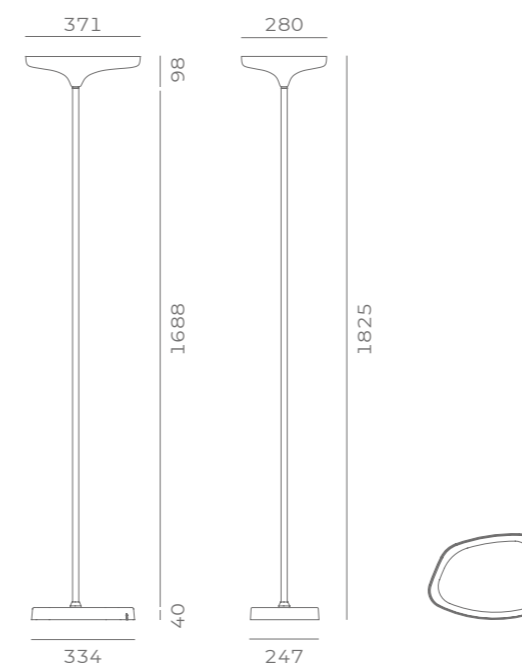

Fonte luminosa
Light source

Temperatura colore
Colour temperature

Flusso luminoso
Luminous flux

Finiture
Finishing

da/from
23 W
a/to
27 W

3000 K
4000 K

2500 lm

nero lucido
polished black
bianco lucido
polished white



25 W

RGBW (HUE)

2000 lm

Corpo PMMA lucido **Diffusore** PMMA satinato
Body polished PMMA **Diffuser** satin PMMA

IP20





flat p

design **Gianpietro Tonetti**

Flat è un apparecchio installabile a parete che si staglia deciso e tridimensionale sulla superficie. La sua luce diffusa arreda e personalizza gli ambienti, senza dimenticarne le qualità tecnologiche. Disponibile nella versione white, con temperatura colore 3000 K - 4000 K o RGBW, per la massima personalizzazione delle atmosfere luminose.

Flat is a wall-mounted light which is decisive and three-dimensional on the surface. Its diffused light furnishes and customises spaces without forgetting their technological qualities.

Available in the white version, with colour temperature of 3000 K - 4000 K or RGBW, for maximum customisation of light atmospheres.

flat parete wall

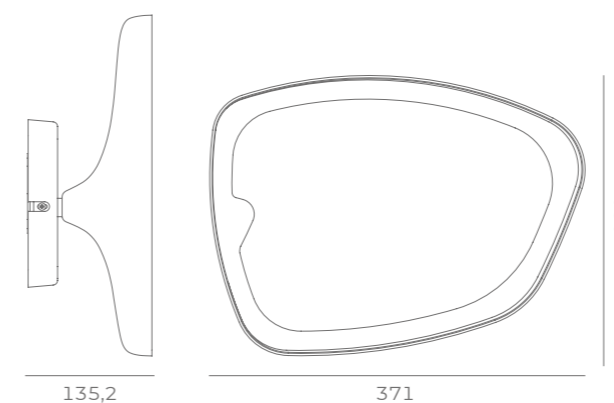

Fonte luminosa Light source	Temperatura colore Colour temperature	Flusso luminoso Luminous flux	Finiture Finishing
da/from 23 W	3000 K	2500 lm	nero lucido polished black
a/to 27 W	4000 K		bianco lucido polished white
26 W	RGBW (HUE)	2000 lm	

Corpo PMMA lucido **Diffusore** PMMA satinato
Body polished PMMA **Diffuser** satin PMMA

IP20



esperienza di
luce e colore.
un design con
personalità.

*light and colour experience.
design with personality.*







globe

Un globo sferico sospeso. Globe è una sorgente di luce uniforme e totale; illumina in modo diffuso l'ambiente, senza rischio di abbagliamento. Ideale per installazioni di design all'interno di abitazioni e luoghi pubblici come ristoranti e bar, con un tocco vintage.

A suspended spherical globe. Globe is a uniform, total light source. It lights spaces in a diffused manner, without the risk of dazzling. Ideal for design installations in homes and public spaces such as restaurants and bars, with a touch of vintage.



globe

design **Giorgio Motta**

Apparecchio a sospensione con corpo in polietilene opale per un'illuminazione diffusa e uniforme. Disponibile in due dimensioni, Ø 600 mm / Ø 800 mm è installabile in ambienti indoor di ogni tipologia, ha una potenza massima di 38 W e un flusso luminoso in grado di raggiungere i 6850 lm.

A pendant light with opal polyethylene body for diffused, uniform lighting. Available in two sizes, Ø 600 mm / Ø 800 mm it can be installed in indoor spaces of every type, with a maximum power of 38 W and a maximum light flow of 6850 lm.

globe

sospensione *suspension*

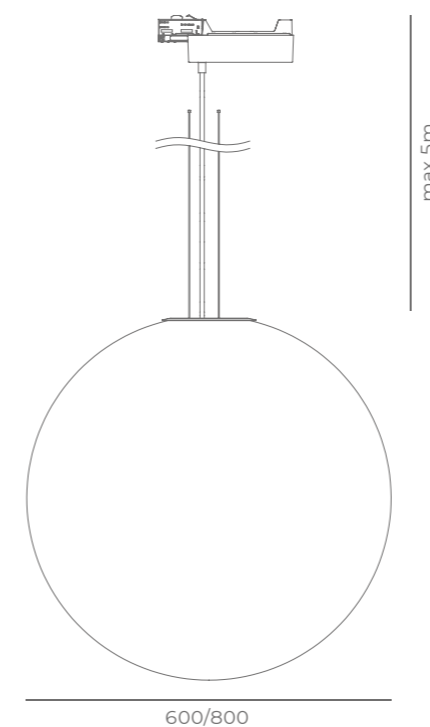

Fonte luminosa <i>Light source</i>	Temperatura colore <i>Colour temperature</i>	Flusso luminoso <i>Luminous flux</i>	Finiture <i>Finishing</i>
da/from 27 W	3000 K	da/from 4400 lm	bianco opale <i>opal white</i>
a/to 38 W	4000 K	a/to 6850 lm	

Corpo polietilene
Body polyethylene

IP20 **Symphonica**
SMART SOUND

ilios

La luce di Ilios si diffonde con grazia negli ambienti, contribuendo a trasmettere un senso di armoniosa accoglienza. Mimetismo totale per un effetto scenico che affascina, senza rinunciare all'efficienza. Disponibile in quattro versioni: incasso, proiettore fisso e mobile e sospensione. Tutti i modelli possono essere dotati di una lente concentrante in PMMA di 12° per generare fasci luminosi stretti e definiti. Nella serie standard viene abbinato ad IRIS, un LED specifico per un'elevata resa cromatica.

The light from Ilios spreads over spaces with grace, helping to give a welcoming harmonious atmosphere. Total mimetism for a charming scenic effect, without forfeiting efficiency. Available in four versions: flush-mounted, fixed and moveable projector and pendant. All models can be fitted with a 12° concentrating lens in PMMA to generate narrow, defined light beams. In a standard version it is combined with IRIS, a specific LED with a high chromatic yield.

NORTH SAILS



iris led

iris led

Ilios viene abbinato ad **IRIS**, un LED specifico per una elevata resa cromatica in grado di esaltare l'**intensità dei colori caldi** e, allo stesso tempo, la **brillantezza dei bianchi**. Ideato per un'enfasi superiore di colori e materiali.

*Ilios is combined with **IRIS**, a specific LED for high colour rendering to simultaneously enhance the **intensity of warm colours** and the **brilliance of whites**. For a greater emphasis of colours and materials.*



ilios i

Invisibile e orientabile, Ilios I è un apparecchio ad incasso con riflettore in policarbonato con metal coating in alluminio.

Il corpo è realizzato in alluminio verniciato a polvere epossidica e disponibile con finitura nera o bianca.

Invisible and adjustable, Ilios is a flush-mounted light with a metal-coated aluminium polycarbonate reflector. The body is made in epoxy-powdered painted aluminium and is available with a black or white finish.

ilios incasso recessed

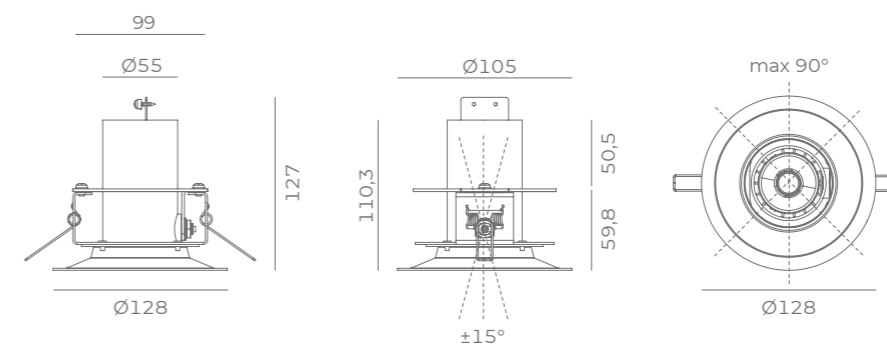

Fonte luminosa Light source	Temperatura colore Colour temperature	Riflettori Reflectors	Flusso luminoso Luminous flux	Finiture Finishing
da/from 9 W	2700 K 3000 K 4000 K	S 31° M 36° L 47°	da/from 920 lm	nero opaco matt black
a/to 14 W	iris neutral iris cold	versione lens/ lens version 11°	a/to 2160 lm	bianco opaco matt white

Corpo estrusione di alluminio verniciato a polvere epossidica **Riflettore** policarbonato con metal coating in alluminio
Body aluminium extrusion epoxy powder coated **Reflector** polycarbonate with aluminium metal coating



ilios p

Connotato da uno snodo del braccio posizionato sull'estremità inferiore del corpo illuminante, si contraddistingue per uno stile contemporaneo ed essenziale.

Distinguished by an articulation on the arm positioned at the lower end of the lighting body, it stands out for its contemporary and clean-cut style.

ilios proiettore projector

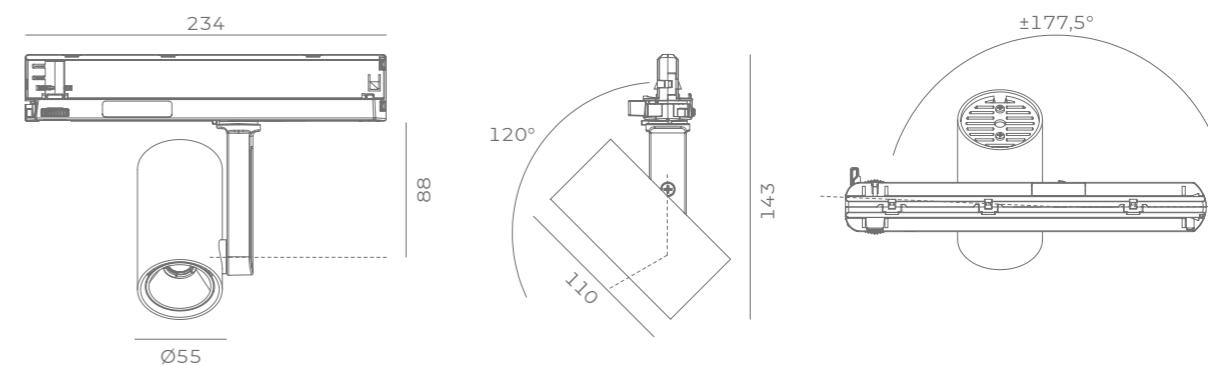

Fonte luminosa Light source	Temperatura colore Colour temperature	Riflettori Reflectors	Flusso luminoso Luminous flux	Finiture Finishing
da/from 9 W	2700 K	S 31°	da/from 920 lm	nero opaco matt black
a/to 14 W	3000 K	M 36°	a/to 2160 lm	bianco opaco matt white
	4000 K	L 47°		
	iris neutral	versione lens/ lens version		
	iris cold	11°		

Corpo estrusione di alluminio verniciato a polvere epossidica **Riflettore** policarbonato con metal coating in alluminio
Body aluminium extrusion epoxy powder coated **Reflector** polycarbonate with aluminium metal coating

ilios up



Una rivoluzione nel suo genere: Ilios UP è un proiettore che, oltre ad essere installato sul binario a sospensione, è dotato di un braccio mobile che permette di orientare la luce anche verticalmente, con un fascio luminoso più ampio e, allo stesso tempo, preciso.

A revolution of its kind: Ilios UP is a projector which is not only installed on a suspension track but is also fitted with a moveable arm which makes it possible to direct the light even vertically, with a wider, and at the same time, more accurate light beam.

ilios proiettore projector

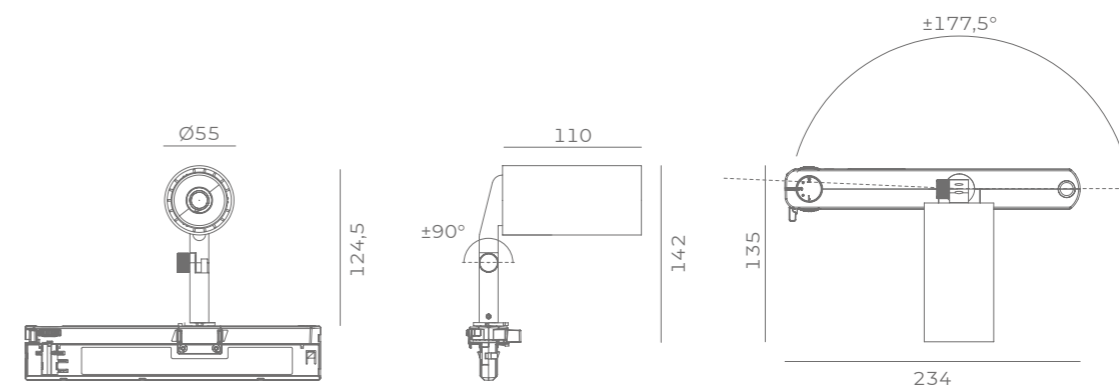

Fonte luminosa Light source	Temperatura colore Colour temperature	Riflettori Reflectors	Flusso luminoso Luminous flux	Finiture Finishing
da/from 9 W	2700 K	S 31°	da/from 920 lm	nero opaco matt black
a/to 14 W	3000 K	M 36°	a/to 2160 lm	bianco opaco matt white
	4000 K	L 47°		
	iris neutral	versione lens/ lens version		
	iris cold	11°		

Corpo estrusione di alluminio verniciato a polvere epossidica **Riflettore** policarbonato con metal coating in alluminio
Body aluminium extrusion epoxy powder coated **Reflector** polycarbonate with aluminium metal coating

Rigorosa nelle forme, è ideale per un'illuminazione localizzata e accurata mediante punti luce singoli o multipli.

Rigorous in shape, it is ideal for localized and accurate lighting through single or multiple light points.



ilios s

ilios

sospensione *suspension*

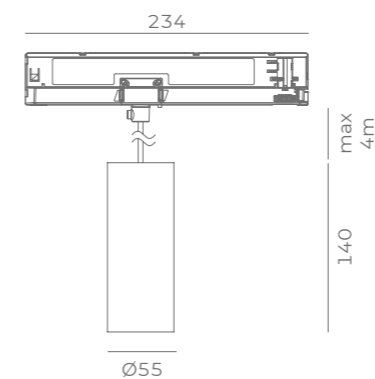

Fonte luminosa <i>Light source</i>	Temperatura colore <i>Colour temperature</i>	Riflettori <i>Reflectors</i>	Flusso luminoso <i>Luminous flux</i>	Finiture <i>Finishing</i>
da/from 9 W	2700 K	S 31°	da/from 920 lm	nero opaco <i>matt black</i>
a/to 14 W	3000 K	M 36°	a/to 2160 lm	bianco opaco <i>matt white</i>
	4000 K	L 47°		
	iris neutral	versione lens/ <i>lens version</i>		
	iris cold	11°		

Corpo estrusione di alluminio verniciato a polvere epossidica **Riflettore** policarbonato con metal coating in alluminio
Body aluminium extrusion epoxy powder coated **Reflector** polycarbonate with aluminium metal coating



lo spazio si rivela.

the space is revealed.



kassandra

Kassandra è una sospensione con struttura in metallo e paralume in tessuto, personalizzabile nei colori e nelle grafiche a seconda dei desideri e delle necessità di ambientazione.

Kassandra is a pendant light with a metal structure and lamp shade in fabric, customisable in colours and decorations to satisfy the wishes and needs of the space.



kassandra



Apparecchio a sospensione disponibile in versione DALI e dimmerabile. Kassandra emette una luce diffusa per un'illuminazione mai invasiva o disturbante.

A pendant light available in DALI and dimmable versions. Kassandra emits a diffused light for a lighting that is never invasive or disturbing.

kassandra sospensione *suspension*

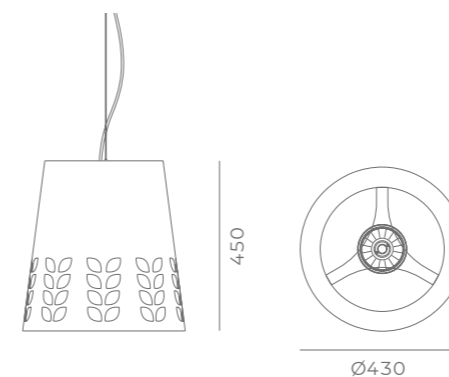





Fonte luminosa
Light source

Temperatura colore
Colour temperature

Riflettori
Reflectors

Flusso luminoso
Luminous flux

Finiture
Finishing

				blu opaco - spiga di grano <i>matt blue - ear of corn</i> 
da/from 31 W	2700 K 3000 K	E 48°	da/from 2500 lm	verde opaco - foglia <i>matt green - leaf</i> 
a/to 36 W	4000 K meat plus	U 55°	a/to 5800 lm	rosso opaco - spiga di grano <i>matt red - ear of corn</i> 
20 W (E27)	meat hd	X 64°		tortora opaco - spiga di grano <i>matt turtledove - ear of corn</i> 

Corpo tessuto
Body fabric

IP20

DALI





[...] i miei giusti
presagi hanno
acceso il cielo. [...]

[...] my right forebodings have lit up the sky. [...]

Wisława Szymborska, Monologue for Cassandra

koal

Ideale per il Fashion Retail, è un sistema lineare all-in-one che integra in sé più tipologie di illuminazione: diretta, indiretta, diffusa e d'accento. La sua struttura, caratterizzata da un profilo ad H, permette di ospitare sia sulla parte inferiore che superiore una serie di corpi illuminanti, indipendenti tra loro e gestiti separatamente, per enfatizzare punti del negozio o i prodotti in tutti i loro dettagli o illuminare, in modo equilibrato, gli spazi di circolazione e relax.

Ideal for Fashion Retail, this is a linear all-in-one system which combines several types of lighting: direct, indirect, diffused and accent. Its structure, featuring an H profile, allows a series of independent separately managed lighting bodies to be installed either at the top or the bottom to emphasise points of the store or the products in all their details or to light up walk-ways and relaxation areas in a balanced manner.



Koal è un sistema lineare in grado di ospitare, nella parte superiore, un binario trifase sul quale è possibile installare diverse tipologie di proiettori tra cui spicca ILIOS UP, appositamente progettato per questo sistema. La sezione sottostante può accogliere sorgenti luminose per un'illuminazione diffusa o d'accento, orientabile e personalizzabile. L'elemento può essere inserito in configurazione stand alone o in fila continua.

Koal is a linear system containing, at the top, a three-phase track on which various types of projectors can be installed, including ILIOS UP, specially designed for this system. The section underneath can house light sources for diffused or accent, adjustable and customisable lighting. The element can be inserted in stand alone configuration or in a continuous row.

koal



koal

sospensione *suspension*



Fonte luminosa <i>Light source</i>	Temperatura colore <i>Colour temperature</i>	Flusso luminoso <i>Luminous flux</i>	Finiture <i>Finishing</i>
da/from 33 W	3000 K	da/from 5300 lm	nero opaco <i>matt black</i>
a/to 90 W	4000 K	a/to 15400 lm	bianco opaco <i>matt white</i>

Corpo estrusione di alluminio verniciato a polvere epossidica
Body aluminium extrusion epoxy powder coated

IP20

DALI



lady

Lady, sinonimo di eleganza, è una sospensione che arreda. Disponibile in versione mono o bicolore grazie alla personalizzazione dell'abbinamento colori caratterizza ogni ambiente con decisione.

Lady, synonymous with elegance, is a pendant light that furnishes. Available in single or bi-colour versions thanks to the customisation of the colour combination, it characterises every space decisively.





lady

Apparecchio a sospensione per interni dal design minimale disponibile con le tecnologie DALI e CASAMBI e dimmerabile.

A pendant light for interiors with a minimal design available with DALI and CASAMBI technologies and in dimmable versions.

lady sospensione *suspension*

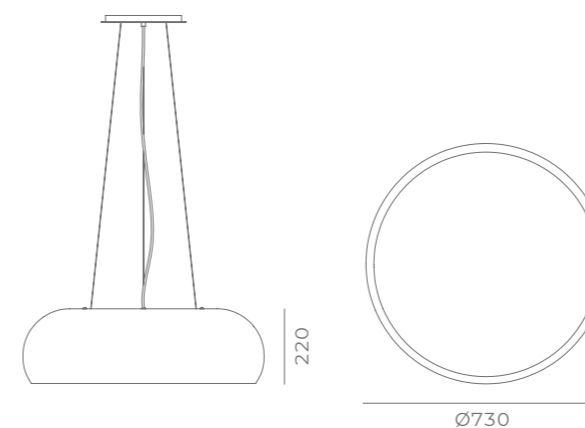

Fonte luminosa <i>Light source</i>	Temperatura colore <i>Colour temperature</i>	Flusso luminoso <i>Luminous flux</i>	Finiture <i>Finishing</i>
40 W	3000 K 4000 K	da/from 4200 lm a/to 4400 lm	in bianco - out rosso <i>in white - out red</i>  in bianco - out nero <i>in white - out black</i>  in nero opaco - out nero lucido <i>in matt black - out polished black</i>  PMMA colorato lucido <i>polished colored PMMA</i> 

Corpo PMMA colorato
Body colored PMMA



malibu

Malibu è una lampada a sospensione sinuosa e moderna. Un apparecchio bicolore, disponibile in differenti finiture esterne, per la massima versatilità di ambientazione. Perfetto per tutti gli ambienti indoor, rende particolare lo spazio, con un tocco di design moderno e mai banale.

Malibu is a sinuous, modern pendant light. A bi-coloured devise, available in different external finishes, to give maximum versatility to the environment. Perfect for all indoor areas, it makes the space special, with a touch of modern design and is never banal.



malibu



Sospensione in alluminio pressofuso con campana realizzata in acciaio verniciato. Apparecchio con potenza 31 W, ed output luminoso che raggiunge i 5800 lm.
Eventualmente disponibile dimmerabile e integrabile con la tecnologia DALI.

*Pendant in die-cast aluminium with shade made in painted steel. A device with a power of 31 W, and a maximum light output of 5800 lm.
Available if required in dimmable version and it can be combined with DALI technology.*

malibu sospensione *suspension*

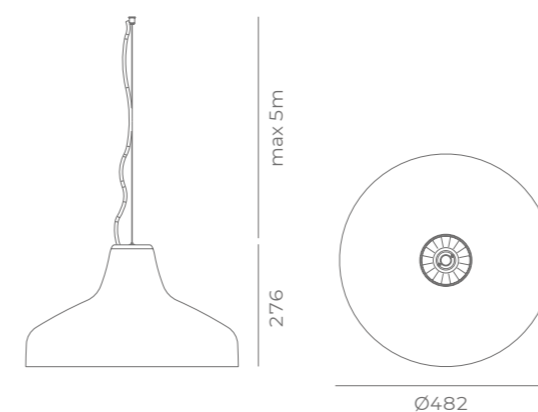

Fonte luminosa <i>Light source</i>	Temperatura colore <i>Colour temperature</i>	Riflettori <i>Reflectors</i>	Flusso luminoso <i>Luminous flux</i>	Finiture <i>Finishing</i>
da/from 31 W	2700 K	S 18°	da/from 2500 lm	nero opaco <i>matt black</i>
a/to 36 W	3000 K	M 22°		bianco opaco <i>matt white</i>
20 W (E27)	4000 K	L 35°	a/to 5800 lm	alluminio verniciato opaco <i>matt coated aluminium</i>
	meat hd	E 48°		
	meat plus	U 55°		
		X 64°		
		Y 75°		
		I 90°		

Corpo alluminio verniciato
Body coated aluminium

IP20

DALI





the sky is more
blue, in malibu.

moses

Moses è una lampada da terra dalla forma iconica, ispirata e tridimensionale. La luce è soffusa ed emozionale, emanata dall'apice del corpo e dai tagli longitudinali impressi sui quattro lati del corpo metallico. La piantana si presenta preziosa nella finitura argento, particolarmente esile nel doppio stelo e con intensità emissive differenti.

Moses is a floor light with an iconic, inspired, three-dimensional shape. The light is suffused and emotional, emitted from the top of the structure and from cuts made in the four sides of the metallic body. This floor lamp features a precious silver finish, with a particularly graceful double stem shape and different intensity emissions.



comando vocale voice control

Moses è design e tecnologia. La sinuosità della strip luminosa definisce e modella la silhouette luminescente di un uomo con bastone, a reminiscenza dell'iconico mito biblico da cui prende il nome. La struttura di acciaio e polimeri ospita il driver e il modulo di **collegamento Wi-Fi** grazie al quale la lampada offre la possibilità di controllare le prestazioni tecnologiche tramite **comando vocale** come Google e Alexa. È possibile interagire direttamente con Moses in modo intelligente e dinamico.

*Moses is design and technology. The sinuous nature of the light strip defines and models the luminous silhouette of a man with a staff, a reference to the Biblical icon that it is named after. The structure is in steel and polymers, containing the driver and module **connecting Wi-Fi** with the current **voice control** instruments (Google - Alexa).*

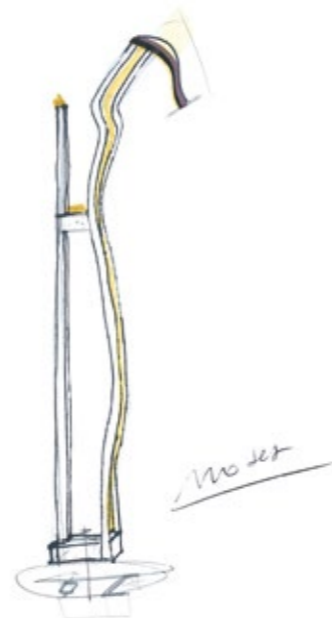



moses

design **Cinzia Anguissola**

Il movimento a U assomma le speculari emissioni LED realizzando l'esito previsto dell'aumento luminoso nell'arcata interna dell'apparecchio. Sulla sommità, sul lato in esterno alla U, lo stelo si dilata e alloggia un'autonoma fonte luminosa d'accento che indirizza il suo fascio verso l'ambiente. La piantana è sostenuta da due dissimili sottili piastre in acciaio argentato e tuttavia tra loro inscrivibili e concentriche. La base a terra, un cerchio da 40 cm, impernia il sovrastante ovale rotante (40 x 29 cm). L'espedito geometrico delle sagome difformi sovrapposte esibisce dinamismo alla rotazione di Moses sul proprio asse.

The U movement collects the specular LED outputs creating the envisaged result of increasing light in the internal arch of the device. At the top, on the outer side of the U, the stand dilates and houses an independent accent light source which directs its beam towards the space. The stand is supported by two dissimilar, slender silver-plated, inscribable, concentric plates. The floor base, a 40 cm circle, is pivoted to the rotating oval (40 x 29 cm) below. The geometric expedient of the dissimilar superimposed shapes demonstrates dynamism with the rotation of Moses on its own axis.

moses piantana floor

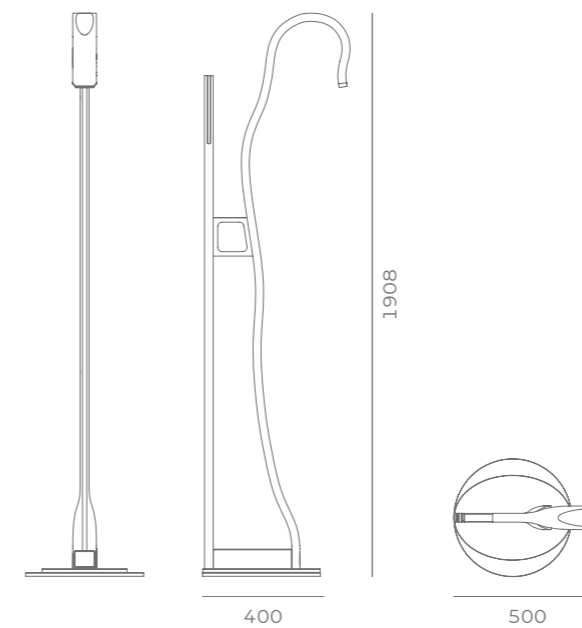

Fonte luminosa Light source	Temperatura colore Colour temperature	Flusso luminoso Luminous flux	Finiture Finishing
testa/head 12 W profilo/profile 25 W	3000 K	testa/head 1200 lm profilo/profile 1800 lm	argento caldo warm silver

Corpo acciaio inox con verniciatura doppio strato
Body stainless steel with double layer painting

IP20 **DALI** **CASAMBI**



numa

Sospensione lineare e pulita, una forma perfetta di pura luce. Numa è un parallelepipedo luminoso, potente e performante, perfetto per installazioni indoor in spazi e aree di lavoro come uffici.

A linear clean pendant light with a perfect shape of pure light. Numa is a luminous, powerful and performing parallelepiped, perfect for indoor installations in work spaces and areas such as offices.



numa

Apparecchio a sospensione con corpo quadrato in lamiera di alluminio con lato 995 mm e altezza 203 mm. Una lampada potente, dotata di sorgente LED 121 W di potenza e flusso luminoso 17000 lm con temperatura 3000 K - 4000 K e integrabile con le più avanzate tecnologie. Lo schermo in PMMA opale assicura la luce migliore anche in contesti di larga metratura, senza il minimo rischio di abbagliamento.

A pendant device with square body in aluminium plate with side measuring 995 mm and a height of 203 mm. A powerful light, equipped with 121 W LED source and 17000 lm light source with temperature of 3000 K - 4000 K. It can be combined with the most advanced technologies. The opal PMMA screen guarantees the best light even in very large contexts, without the minimum risk of dazzling.

numa sospensione *suspension*

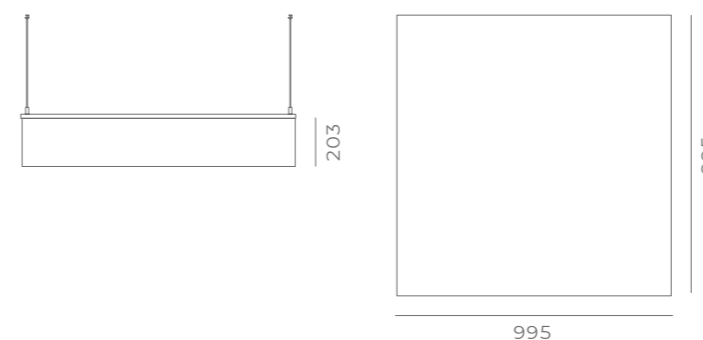

Fonte luminosa <i>Light source</i>	Temperatura colore <i>Colour temperature</i>	Flusso luminoso <i>Luminous flux</i>	Finiture <i>Finishing</i>
121 W	3000 K 4000 K	da/from 16840 lm a/to 17000 lm	PMMA bianco opale <i>opal white PMMA</i>

Corpo PMMA opale, ferro
Body opal PMMA, iron

IP20

DALI



Corpo rotondo in lamiera di alluminio con diametro 600/910 mm e altezza 170 mm per Numa T, apparecchio a sospensione potente, dotato di sorgente LED 121 W di potenza e flusso luminoso 17000 lm con temperatura 3000 K - 4000 K e integrabile con le più avanzate tecnologie. Lo schermo in PMMA opale assicura la luce migliore anche in contesti di larga metratura, senza il minimo rischio di abbagliamento.

Round body in aluminium plate with diameter measuring 600/910 mm and a height of 170 mm for Numa T, pendant device with a powerful light, equipped with 130 W LED source and 17000 lm light source with temperature of 3000 K - 4000 K. It can be combined with the most advanced technologies. The opal PMMA screen guarantees the best light even in very large contexts, without the minimum risk of dazzling.

numa t



numa t sospensione *suspension*

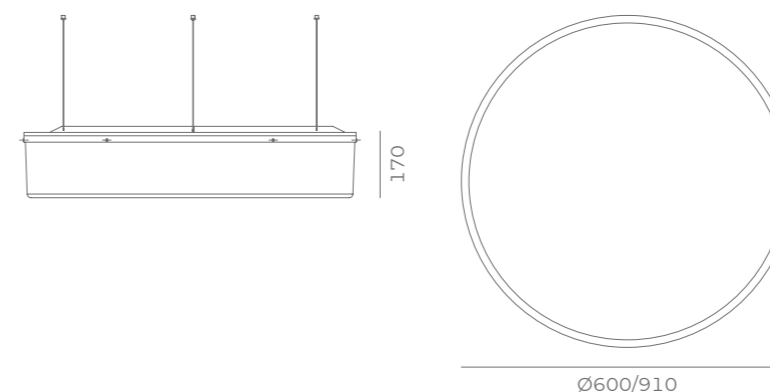

Fonte luminosa <i>Light source</i>	Temperatura colore <i>Colour temperature</i>	Flusso luminoso <i>Luminous flux</i>	Finiture <i>Finishing</i>
da/from 41 W a/to 83 W	3000 K 4000 K	da/from 7600 lm a/to 14800 lm	PMMA bianco opale <i>opal white PMMA</i>

Corpo PMMA opale, ferro
Body opal PMMA, iron

IP20

DALI





orbital

Dall'incontro tra forme pure ed aggraziate e nuovi linguaggi espressivi nasce Orbital, una soluzione ad incasso, un'icona che si configura come elemento di continuità tra il mondo costruito e quello naturale. Una rappresentazione del design organico ove struttura, materiale e funzione sono in perfetta armonia, proprio come avviene nel nostro ecosistema.

Orbital is the result of the marriage of pure and beautiful shapes with new expressive languages, and is a flush-mounted solution, an icon expressed as an element of continuity between the constructed and natural worlds. A representation of organic design where structure, material and function are in perfect harmony, just as in our eco-system.

A
auditorium

Una nuova immagine per il classico 60x60 grazie al corpo realizzato in PMMA, che prende forma in funzione dell'emissione luminosa e integra, in un mimetismo totale, la sorgente, lasciando fruire l'eleganza della luce. Disponibile in colorazione classica e versione traslucente è ideale per migliorare la qualità della percezione visiva all'interno di uffici e di aree comuni quali sale conferenze, hall e corridoi.

A new image for the classical 60x60 thanks to the body made in PMMA, which takes shape according to the light output and integrates the source in total mimetism, allowing the elegance of the light to benefit. Available in classic colours and translucent version, it is ideal to improve the quality of visual perception in offices and communal areas such as conference rooms, halls and corridors.



orbital

orbital

incasso recessed

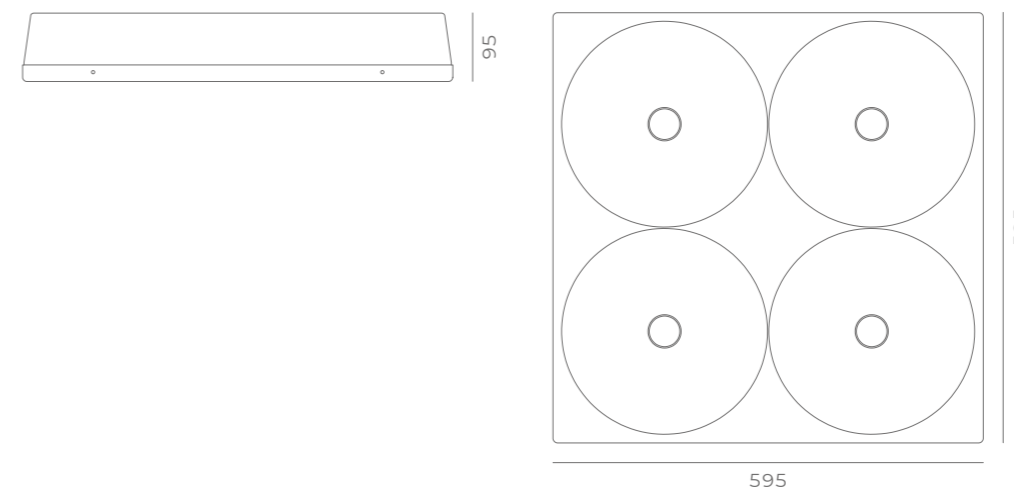

Fonte luminosa Light source	Temperatura colore Colour temperature	Flusso luminoso Luminous flux	Finiture Finishing
70 W	3000 K	da/from 12000 lm	nero lucido polished black
		a/to 12500 lm	nero opaco matt black
	4000 K	a/to 12500 lm	bianco lucido polished white
			bianco opaco matt white

Corpo PMMA, alluminio
Body PMMA, aluminium

IP20

DALI





pagoda

Pagoda è ispirata alla più antica forma di architettura buddista. Una struttura slanciata verso l'alto dove la luce diventa elemento tangibile, quasi materico, con cui valorizzare spazi di vendita.

Pagoda is inspired by the most ancient form of Buddhist architecture. A structure reaching upwards where light becomes the tangible, almost of matter, element, with which to enhance sale spaces.

pagoda



Luce come elemento di accoglienza: Pagoda è dotata di uno schermo microprismatico, garanzia di un comfort visivo ottimale, ed è realizzata in PMMA da verniciare nel colore che meglio si abbina alla zona da illuminare. La luce di Pagoda è dimmerabile, ed è integrabile con le migliori tecnologie avanzate, unendo efficienza e risparmio energetico a qualsiasi esigenza illuminotecnica.

Light as a welcoming element: Pagoda is equipped with a microprismatic screen, a guarantee of optimal visual comfort, and made in PMMA to be painted in the best colour to suit the zone to be lit. Pagoda light is dimmable, and can be combined with the best advanced technologies, combining efficiency and energy saving with any technical-lighting requirement.

pagoda sospensione *suspension*

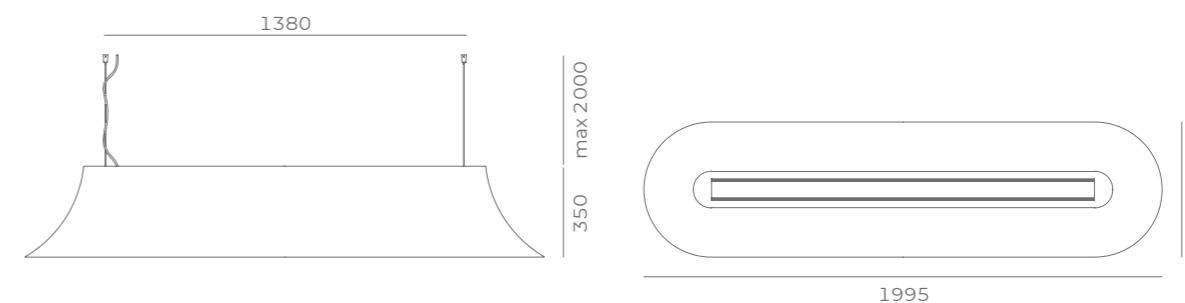

Fonte luminosa <i>Light source</i>	Temperatura colore <i>Colour temperature</i>	Flusso luminoso <i>Luminous flux</i>	Finiture <i>Finishing</i>
da/from 32 W	3000 K	da/from 5000 lm	in bianco - out nero in white - out black
a/to 44 W	4000 K	a/to 7200 lm	in bianco - out blu in white - out blue
			PMMA verniciato opaco matt painted PMMA

Corpo PMMA verniciato, schermo microprismatico
Body painted PMMA, microprismatic screen

IP20 **DALI**  DIMMABLE



pinocchio

Una possibilità di personalizzazione estetica infinita per Pinocchio, una lampada a sospensione con corpo conico realizzato in lamiera, per una distribuzione diretta della luce, o in PMMA, per una illuminazione maggiormente uniforme e diffusa.

An infinite possibility of customising the look for Pinocchio, a pendant light with a conical body made in metal plate, for direct light distribution or in PMMA, for a more uniform and diffused lighting.

Sospensione disponibile in tre varianti dimensionali, entrambe riconducibili alla forma del cono. Un elemento di design che arreda e illumina, allo stesso tempo, con la massima efficienza.

Pendant available in three different sizes, both in the shape of a cone. A design element which furnishes and illuminates, at the same time, with maximum efficiency.



pinocchio

pinocchio sospensione *suspension*

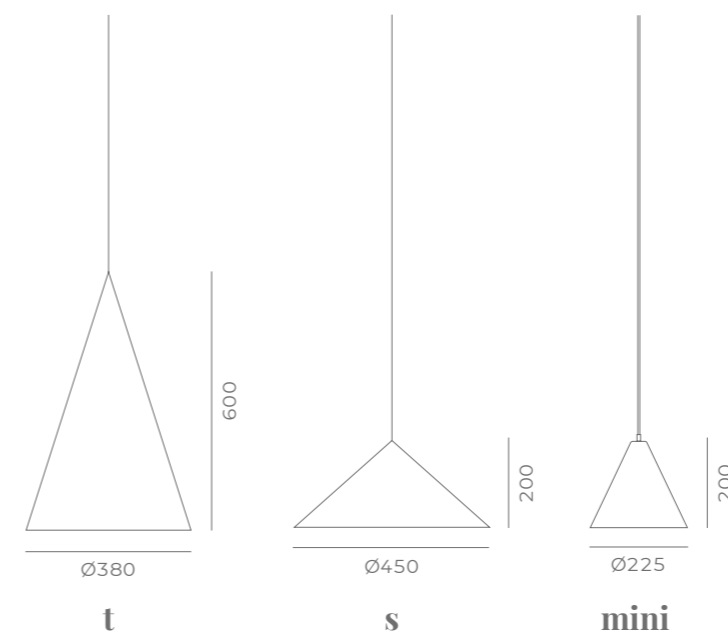

Fonte luminosa
Light source

Temperatura colore
Colour temperature

Flusso luminoso
Luminous flux

Finiture
Finishing

20 W (E27)

2700 K
4000 K

2500 lm

in bianco - out nero
in white - out black
PMMA verniciato opaco
matt painted PMMA



Corpo PMMA verniciato
Body painted PMMA

IP20



integrabile con HUE e CASAMBI
It can be combined with HUE and CASAMBI

spektre

Sopensione LED circolare caratterizzata da un anello in metallo con elemento diffusore in policarbonato. Ideale singolo o combinato con altre varianti per scenografie di luce particolari.

Circular LED pendant light featuring a metal ring with polycarbonate diffuser element. Ideal on its own or combined with other versions for spectacular, special light effects.





spektre

Apparecchio a sospensione con corpo in alluminio estruso e PMMA opale personalizzabili in più finiture. Il diffusore è in policarbonato, la luce è diffusa e scenografica. Spektre è disponibile con potenze differenti sulla base della dimensione (600 mm - 1800 mm) ed è in grado di raggiungere i 25200 lm nella sua variante top. Disponibile anche con tecnologia DALI e dimmerabile.

A pendant light with body in extruded aluminium and opal PMMA customisable in several finishes. The diffuser is in polycarbonate and the light is diffused and spectacular.

Spektre is available with different powers depending on the size (600 mm - 1800 mm) and can reach 25200 lm in its top version. Also available with DALI and dimmable technologies.

spektre

sospensione *suspension*

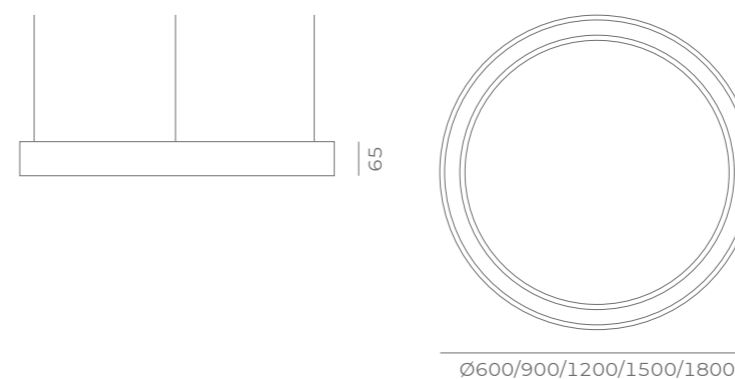

Fonte luminosa
Light source

Temperatura colore
Colour temperature

Flusso luminoso
Luminous flux

Finiture
Finishing

Fonte luminosa <i>Light source</i>	Temperatura colore <i>Colour temperature</i>	Flusso luminoso <i>Luminous flux</i>	Finiture <i>Finishing</i>
da/from 24 W	3000 K	da/from 3740 lm	nero <i>black</i>
a/to 148 W	4000 K	a/to 25200 lm	bianco <i>white</i>
			alluminio opaco <i>matt aluminium</i>

Corpo estruso di alluminio, PMMA opale
Body extruded aluminium, opal PMMA

IP20

DALI



sphera

Corpo emisferico, elegante e di design. Sphera è una sospensione classica, disponibile in tre diverse dimensioni. Un elemento che arreda e si adatta agli spazi. Ideale soprattutto per ambienti commerciali, grazie alla possibilità di personalizzazione del corpo lampada in versione mono o bicolore. La variante Design permette un'ulteriore customizzazione in cui il singolo brand può essere serigrafato o intagliato sul fronte della lampada.

A hemispheric, elegant, design body. Sphera is a classic pendant light, available in three different sizes. A furnishing element which can be adapted to suit spaces. Ideal above all for commercial areas, thanks to the possibility of customising the lamp body in single or bi-colour versions. The Design version allows further customisation in which the individual brand can be screen-printed or engraved on the front of the light.



sphera



Lo stile semplice di Sphera è in grado di dare carattere a spazi di ogni tipo. Un oggetto di design composto da un corpo in PMMA colorato, mono o bicolore, interamente personalizzabile nella scelta e nella composizione delle finiture. L'apparecchio è disponibile con tecnologie DALI e dimmerabile.

Sphera's simple style can give character to spaces of every type. A design object composed of a body in single or bi-coloured PMMA, fully customisable in the choice and composition of finishes.

The device is available with DALI and dimmable technologies.

sphera sospensione *suspension*

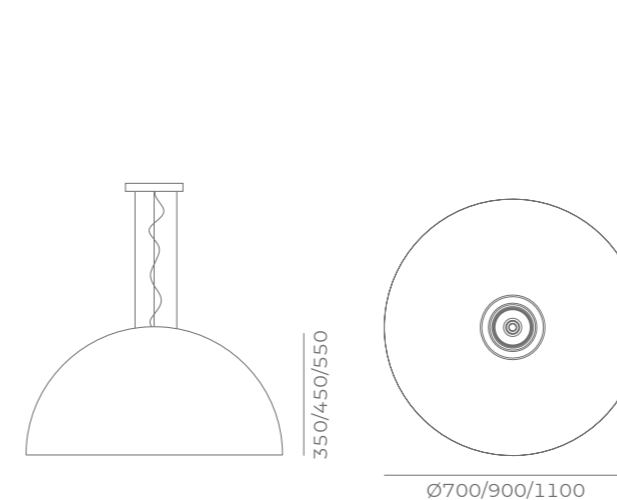

Fonte luminosa <i>Light source</i>	Temperatura colore <i>Colour temperature</i>	Riflettori <i>Reflectors</i>	Flusso luminoso <i>Luminous flux</i>	Finiture <i>Finishing</i>
31 W	3000 K 4000 K	S 18° M 22° L 35° E 48° U 55° X 64° I 90°	<i>da/from</i> 4900 lm <i>a/to</i> 5000 lm	in bianco - out nero <i>in white - out black</i> in rosso - out nero <i>in red - out black</i> in rosso - out bianco <i>in red - out white</i> PMMA colorato lucido <i>polished</i> colored PMMA

Corpo PMMA colorato
Body colored PMMA

IP20

DALI

Symphonica
SMART SOUND





tita

Sospensione LED circolare in alluminio colorato totalmente personalizzabile nella scelta dei colori, per adattarsi a qualsiasi ambiente. Disponibile in tre dimensioni e anche nelle versioni a plafone e a parete.

A circular LED pendant light in coloured aluminium, totally customisable in the choice of colours, so that it can be adapted to any space. Available in three sizes and also in ceiling and wall versions.



tita

Tita, apparecchio con corpo in alluminio estruso e schermo in PMMA opale, è integrabile con la tecnologia DALI. La sua luce è diffusa e raggiunge una potenza massima di 152 W, nella versione di dimensioni maggiori.

Tita, a device with extruded aluminium body and opal PMMA screen, it can be combined with DALI technology. Its light is diffused and can reach a maximum power of 152 W, in the larger version.

tita
sospensione *suspension*

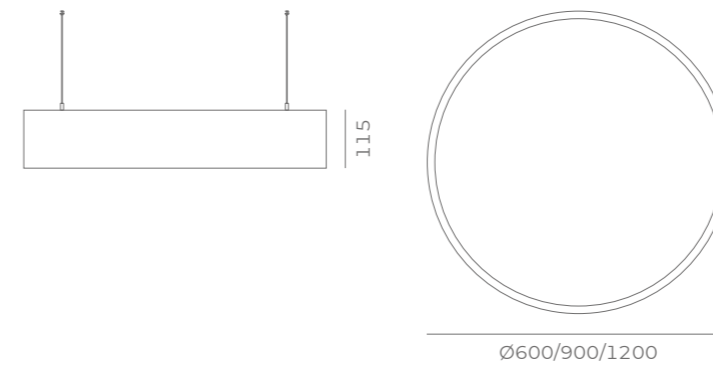

Fonte luminosa <i>Light source</i>	Temperatura colore <i>Colour temperature</i>	Flusso luminoso <i>Luminous flux</i>	Finiture <i>Finishing</i>
da/from 37 W	3000 K	da/from 6040 lm	nero <i>black</i>
a/to 152 W	4000 K	a/to 26020 lm	bianco <i>white</i>
			alluminio verniciato opaco <i>matt painted aluminium</i>

Corpo estruso di alluminio, PMMA opale
Body extruded aluminium, opal PMMA

IP20 DALI DIMMABLE

Tita, apparecchio con corpo in alluminio estruso e schermo in PMMA opale, è integrabile con la tecnologia DALI. La sua luce è diffusa e raggiunge una potenza massima di 152 W, nella versione di dimensioni maggiori.

Tita, a device with extruded aluminium body and opal PMMA screen, it can be combined with DALI technology. Its light is diffused and can reach a maximum power of 152 W, in the larger version.



tita

tita
plafone *ceiling*



Fonte luminosa <i>Light source</i>	Temperatura colore <i>Colour temperature</i>	Flusso luminoso <i>Luminous flux</i>	Finiture <i>Finishing</i>
da/from 37 W	3000 K	da/from 6040 lm	nero <i>black</i>
a/to 152 W	4000 K	a/to 26020 lm	bianco <i>white</i>
			alluminio verniciato opaco <i>matt painted aluminium</i>

Corpo estruso di alluminio, PMMA opale
Body extruded aluminium, opal PMMA

IP20

DALI





trieste

Trieste è una forma semplice e contemporaneamente complessa, in grado di "muovere" la parete attraverso la luce. Un accento, un'illuminazione d'atmosfera dal linguaggio contemporaneo, un elemento d'arredo dalle infinite strade, grazie alla possibilità di composizione di più prodotti tra loro.

Trieste is a simple and at the same time complex shape, able to "give movement" to the wall with light. An accent, atmospheric lighting with a contemporary language, a furnishing element with infinite solutions, thanks to the possibility of putting more than one product together.



trieste

Lampada installabile a parete con corpo in metallo spazzolato e PMMA satinato. Trieste, essenziale e performante nella sua semplicità, è disponibile con temperatura colore 3000 K - 4000 K.

A light which can be installed on the wall with body in brushed metal and satin-finished PMMA.

Trieste, clean-cut and performing in its simplicity, is available with colour temperature of 3000 K - 4000 K.

trieste parete wall

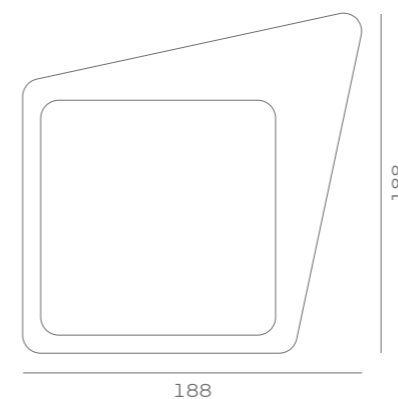

Fonte luminosa <i>Light source</i>	Temperatura colore <i>Colour temperature</i>	Flusso luminoso <i>Luminous flux</i>	Finiture <i>Finishing</i>
6 W	3000 K 4000 K	da/from 850 lm a/to 900 lm	acciaio spazzolato <i>brushed steel</i>  oro spazzolato <i>brushed gold</i>  rame spazzolato <i>brushed copper</i> 

Corpo PMMA satinato, metallo spazzolato
Body satin PMMA, brushed metal

IP20

venezia

Lampada da parete in metallo ideale per una luce di atmosfera e per gli ambienti di passaggio. Il corpo di Venezia è asimmetrico, tridimensionale e personalizzabile in numerose varianti grafiche, per rispondere a qualsiasi tipo di applicazione, adeguarsi ad ogni arredo, esprimere le più estrose creatività.

Wall lamp in metal ideal for walk-through areas. The body of Venezia is asymmetrical, three-dimensional and customisable in numerous graphic variations, to satisfy any type of application, to fit in with any type of furniture and to express the most whimsical creativity.



venezia



Venezia è un'applicazione ideale per ambienti interni, con corpo realizzato in alluminio piegato e verniciato totalmente personalizzabile nell'estetica. Massima efficienza e minimo impatto energetico, per la migliore qualità illuminotecnica possibile.

Venezia is an ideal wall fitting for interiors, with a body made in bent, painted aluminium. Its look is totally customisable. Maximum efficiency and minimum energy impact, for the best possible technical-lighting quality.

venezia parete wall

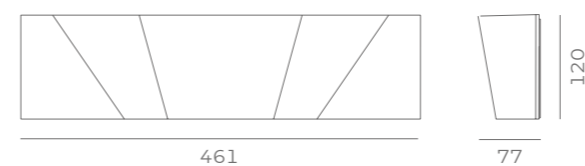

Fonte luminosa Light source	Temperatura colore Colour temperature	Flusso luminoso Luminous flux	Finiture Finishing
2x13 W	3000 K 4000 K	da/from 2x1150 lm a/to 2x1210 lm	bianco white  alluminio verniciato opaco matt painted aluminium 

Corpo lastra di alluminio piegata e verniciata
Body painted aluminium bent sheet

IP20

wayd

Wayd è la sinergia di una doppia visione: design e tecnologia. Una lampada dall'estetica lineare creata per il mondo del lavoro e, allo stesso tempo, strutturata per un apparecchio da terra, caratterizzato da una testa ovale in cui è presente un impianto di diffusione audio. Collegabile alla rete Wi-Fi, può essere controllata anche tramite comando vocale.

Wayd is the synergy of a double vision: design and technology. A light with a linear look created for the working world and, at the same time, structured for a floor device, featuring an oval head housing a sound diffusion system. Linked to the Wi-Fi network, it can also be voice-controlled.



La lampada da terra Wayd è disponibile in diverse finiture per poter ambientare il prodotto al meglio all'interno degli spazi di lavoro nel modo meno invasivo possibile.

Il plus tecnologico aggiuntivo consiste nella possibilità di gestione dell'intensità luminosa, per un'ottimizzazione dei costi e un massimo comfort visivo.

The Wayd floor lamp is available in various finishes so that the product can fit into work spaces in the least invasive way possible. The motion and light intensity management is an additional technological asset to optimise costs and to give maximum visual comfort.

wayd

design **K3m architects**



wayd piantana floor

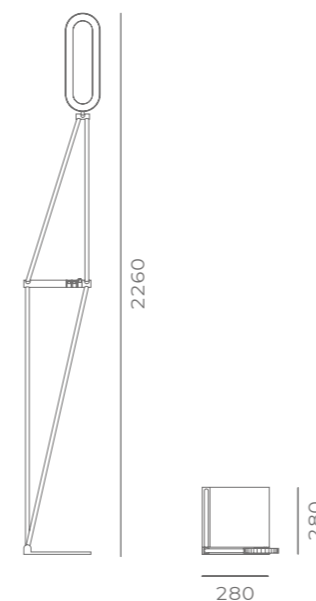

Fonte luminosa
Light source

Temperatura colore
Colour temperature

Flusso luminoso
Luminous flux

Finiture
Finishing

80 W	3000 K	8500 lm	biotite  malachite  palladio  peltrox  titaniox  topazio imperiale  imperial topaz
------	--------	---------	--

Corpo acciaio inox con inchiostrazione superficiale
Body stainless steel with inking surface

IP20

Symphonica
SMART SOUND

 DIMMABLE

 TUNABLE WHITE



wayd is
“what are
you doing?”



inspirations

Qui di seguito un excursus nei **top progetti** che sono il fiore della visione Makris. **Dal retail alla GDO, dalla ristorazione all'abitazione privata**, essi sono l'essenza del modo di essere, di pensare e di lavorare del gruppo.

*A list follows of the **top projects** which are the jewel in the crown of Makris' vision. **From retail to Large Scale Distribution, from restaurants to private homes**, they are the essence of the way the group lives, thinks and works.*



dispensa emilia



crem





wagamama

gelateria sani





chef
kitchen

acqua & sapone





centro piazzalodi



general features

design

Makris è un mondo in continua rivoluzione. La sua essenza vive nell'aver un'identità forte ma interpretabile. Ecco perchè si lascia definire da **menti fervide** dal netto carattere funzionale e creativo.

*Makris is a world in constant revolution. Its essence lives in having a strong but interpretable identity. That is why it allows itself to be defined by **fervid minds** with a clear functional and creative personality.*

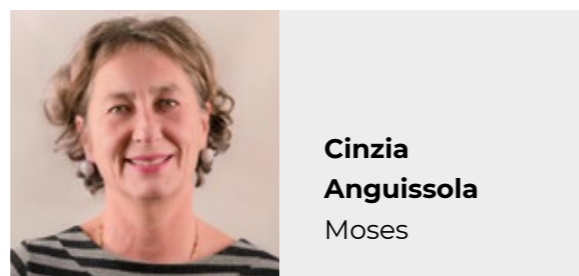

Cinzia Anguissola
Moses

Architetto, designer d'interni, docente. Collaboratrice della collana di design diretta dal critico statunitense Mel Byars, nel 2004 partecipa all'aggiornamento de The Design Encyclopedia per il MOMA, N.Y.

Una figura poliedrica, una forte personalità progettuale, riconoscibile in suo ogni lavoro.

Architect, interior designer, teacher. Collaborator with the design series directed by the American critic Mel Byars, in 2004 she helped update The Design Encyclopedia for the MOMA, N.Y. A versatile person with a strong project-orientated personality, recognisable in her work.

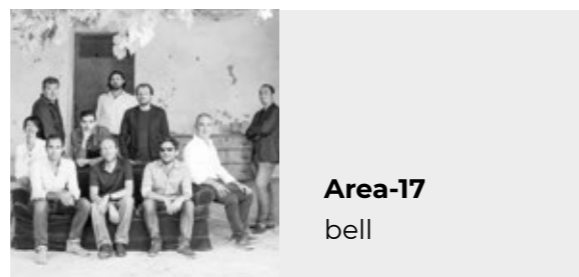

Area-17
bell

Studio di architettura e design d'interni con una filosofia progettuale profondamente radicata nella cultura del design italiano. Firenze nel 2004, i soci si uniscono per operare a livello internazionale attraverso la sinergia tra i componenti del gruppo. Attualmente, Area-17 ha sedi anche a Hong Kong, Shanghai, Pechino e Cuenca (Ecuador), oltre a un media-lab a Sassari.

An architecture and interior design practice with a design philosophy deeply rooted in Italian design culture. Florence in 2004, the partners decided to operate at international level through synergy between the members of the group. Currently, Area-17 also has offices in Hong Kong, Shanghai, Peking and Cuenca (Ecuador), as well as a media-lab in Sassari.

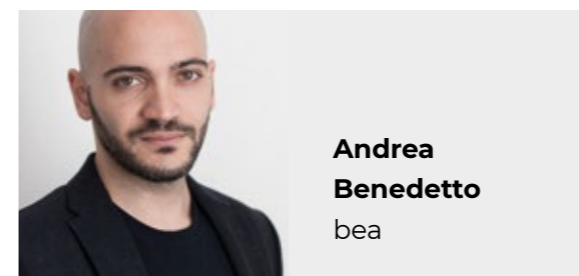

Andrea Benedetto
bea

Una laurea in architettura e una forte passione per la musica. Peregrina tra Roma e Milano lavorando nei migliori studi di progettazione. Oggi è concept designer per Makris, si occupa inoltre di progettazione architettonica, grafica e comunicazione visiva.

A degree in architecture and a strong passion for music. He travels between Rome and Milan, working in the best design practices. Currently a concept designer for Makris, he also works on architectural, graphic and visual communication projects.

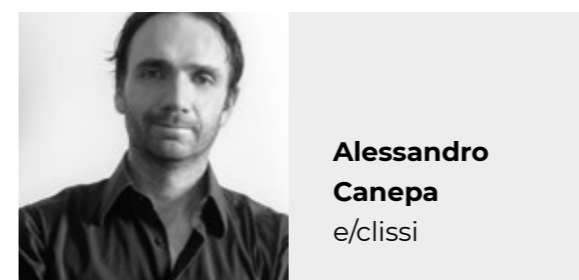

Alessandro Canepa
e/clissi

Dall'osservazione della realtà circostante volta alla continua ricerca della semplicità, della bellezza e della dinamicità. Un designer dall'approccio pragmatico con un'attenzione scrupolosa al particolare ma al tempo stesso una profonda comprensione dell'oggetto nella sua globalità.

From observation of the surrounding reality aimed at constant search for simplicity, beauty and dynamicity. A designer with a pragmatic approach with scrupulous attention to detail but at the same time a profound understanding of the object as a whole.

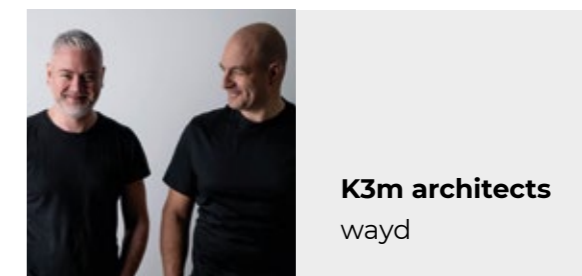

K3m architects
wayd

K3m architects nasce nel 2003 dal sodalizio professionale tra gli architetti Alessandro Iezzi e Fabio Di Sciullo. Un approccio multidisciplinare al processo creativo, specializzato nell'ambito del retail buildings design, dell'housing e della progettazione di strutture ricettive.

K3m architects was founded in 2003 from the professional association of architects Alessandro Iezzi and Fabio Di Sciullo. A multi-disciplinary approach to the creative process, specialised in the retail building design, housing and hotel design spheres.

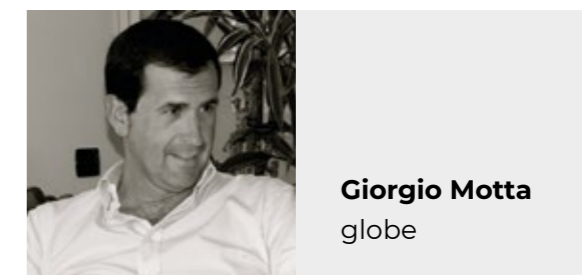

Giorgio Motta
globe

Architetto socio dello studio TP4 Associati, realtà con un'attenzione al dettaglio e alla ricerca di materiali innovativi. Lo studio si occupa di progetti che spaziano dal residenziale al pubblico, con una speciale esperienza nel campo del recupero di aree dismesse in ottica eco-sostenibile.

An architect and partner of the TP4 Associati practice, a reality with attention to detail and search for innovative materials. The practice works on projects ranging from residential to public buildings, with special experience in the field of recovering de-commissioned areas from the eco-sustainability point of view.

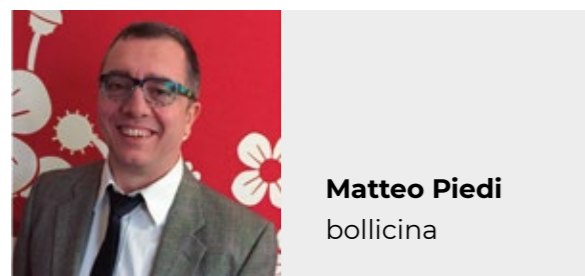

Scenografo di formazione, respira sin da piccolo aria di spettacolo crescendo nella società fondata dal padre, scenografo televisivo. Il retaggio da tecnico artistico gli consente di spaziare dalla progettazione di scenografie e costumi fino all'interior design, passando per la metallurgia in arte e gioielleria.

Set-designer by profession, the entertainment world was in his blood from an early age, growing up in the company founded by his father who was a television set-designer. The heritage of artistic technician allows his work to range from designing sets and costumes to interior design, as well as metallurgy in art and jewellery.

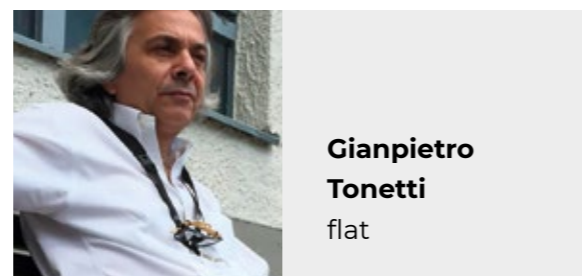

Nato a Cremona nel 1958, ha vissuto e lavorato a Lodi, per le più famose aziende del settore arredamento e design. Dal 2011 sposta le proprie aree di intervento nei più svariati settori industriali sviluppando un'estetica lontana dall'astrattismo formale in ottica di funzionalità prima di tutto, senza mai dimenticare l'aspetto della piacevolezza estetica.

Makris è orgogliosa di poter presentare l'ultimo fiore all'occhiello della Tonettidesign, frutto della visione di Gianpietro Tonetti, scomparso prematuramente nel 2019.

Born in Cremona in 1958, he has lived and worked in Lodi, for the most famous companies in the furniture and design sector. In 2011 he expanded his work areas to the widest range of industrial sectors developing an aesthetic far from formal abstractionism with a view to functionality above all else, without ever forgetting the aspect of pleasing aesthetics. Makris is proud to present the latest jewel in the crown of Tonettidesign, the result of the vision of Gianpietro Tonetti, who passed away prematurely in 2019.

finiture finishes

Estetica ed efficienza. Makris offre un intero catalogo di **finiture disponibili per il massimo della personalizzazione** di ciascuno dei prodotti.

Dalla scelta dei materiali, al colore fino alle finiture interne ed esterne.

*Aesthetics and efficiency. Makris offers a whole catalogue of **finishes available so that each product can be fully personalised.***

From selecting materials, to the colour and internal and external finishes.

PMMA PMMA

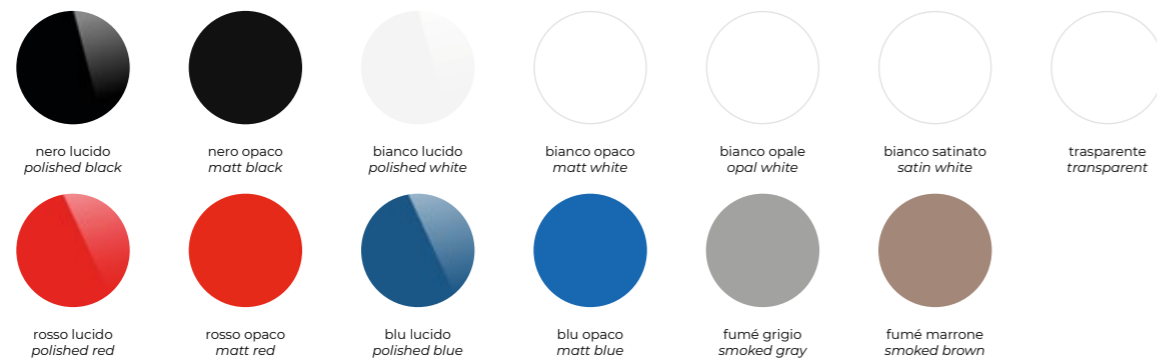

Metalli Metals



Vetro Glass

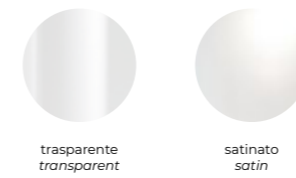

Polietilene Polyethylene

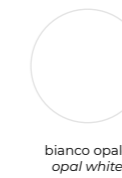

Legno Wood

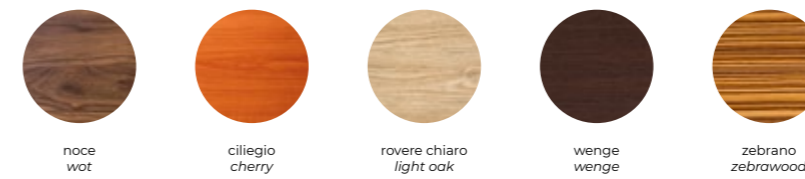

Tessuti Canvas

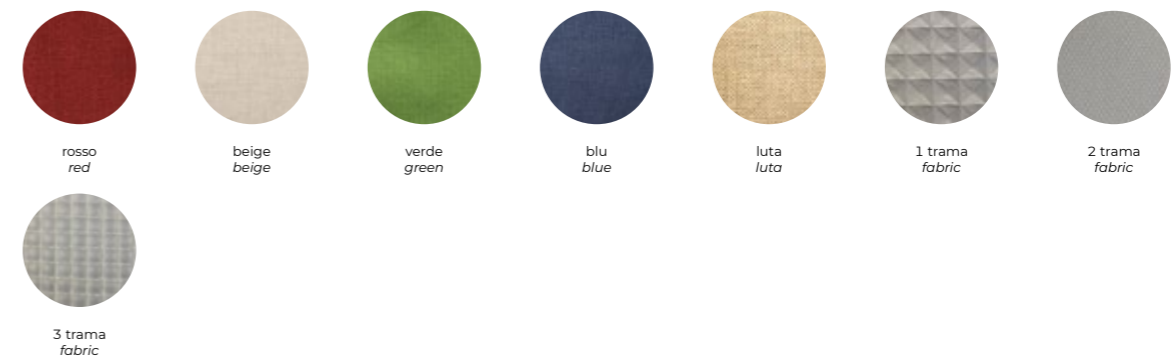

Rete Mesh

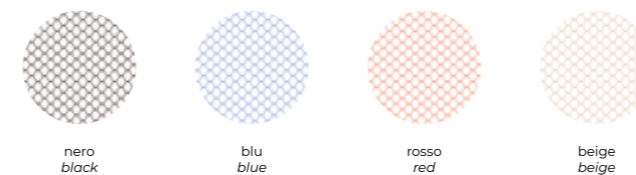

Colori RAL per verniciatura a liquido o a polvere RAL colours for liquid or powder coating

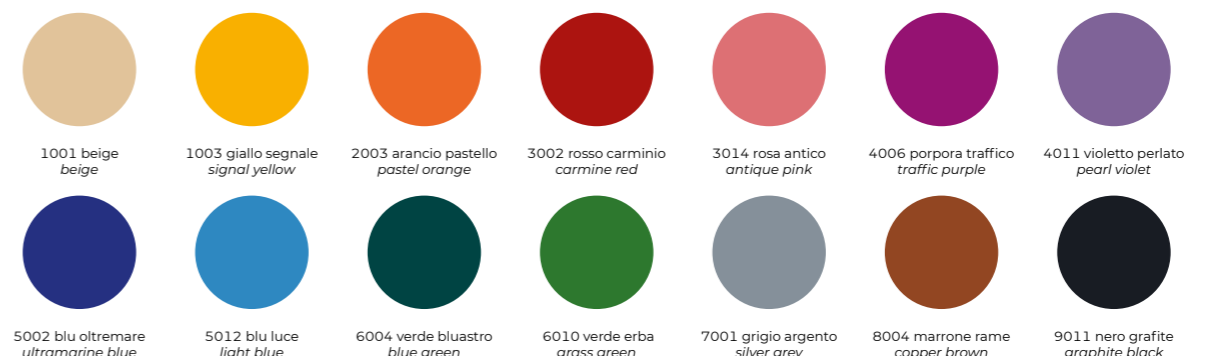

illimitate opzioni colore *unlimited colour options*



Tutti i dati sono indicativi e soggetti ad aggiornamento. Per maggiori informazioni www.makris.it
All data are indicative and subject to change. For more info www.makris.it

rev.1 06-20

